

PARTS CATALOGUE / TECHNICAL GUIDE

Cal. V657A

[SPECIFICATIONS]

Item	Cal. No.	V657A
Movement		 <p style="text-align: center;">(x 1.0)</p>
Movement size	Outside diameter	ø29.5 mm 26.0 mm between 3 o'clock and 9 o'clock sides
	Casing diameter	ø28.8 mm
	Height	3.7 mm
Time indication		<ul style="list-style-type: none"> • Three hands (hour, minute and second) • Chronograph hands (minute, second and 1/10 second) • Date calendar
Driving system		Step motor (3 pcs.)
Additional mechanism		<ul style="list-style-type: none"> • Stopwatch function <ul style="list-style-type: none"> • Measures up to 60 minutes in 1/10 second increments • Split time measurement • Date calendar <ul style="list-style-type: none"> • Instant setting device for date calendar • Train wheel setting device • Electronic circuit reset switch • Demonstration movement of the hands
Loss/gain		Monthly rate at normal temperature range: less than 20 seconds
Regulation system		Nil
Measuring gate by quartz tester		Any gate can be used.
Battery		SEIKO SR920SW, Maxell SR920SW, Sony SR920SW, Eveready 371, Matsushita SR920SW Battery life is approximately 2 years. Voltage: 1.55V
Jewels		0 jewel

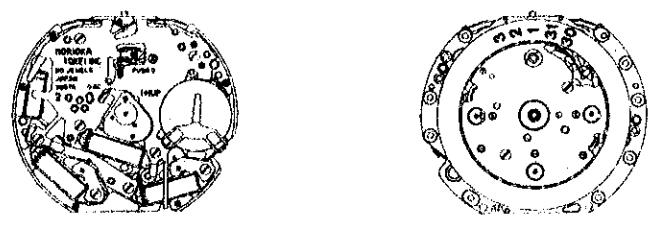

PARTS CATALOGUE

Cal. V657A

Disassembling procedure Figs. : ① → ⑤⑧

Reassembling procedure Figs. : ⑤⑧ → ①

Lubricating: Types of oil Oil quantity

 Moebius A  Normal quantity
 Moebius V

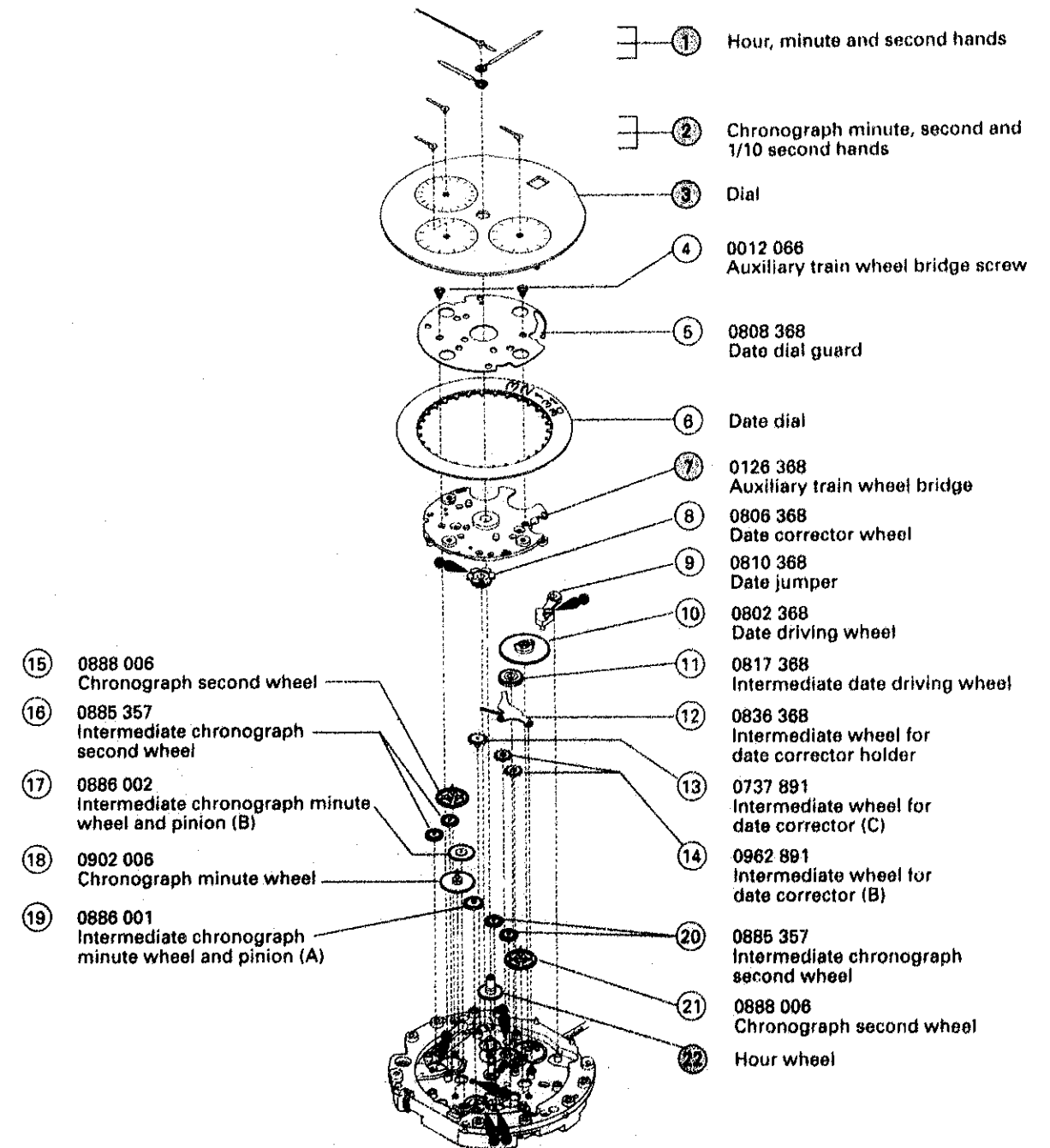

 Please see the remarks on the following pages.



PARTS CATALOGUE

Cal. V657A

PARTS CATALOGUE

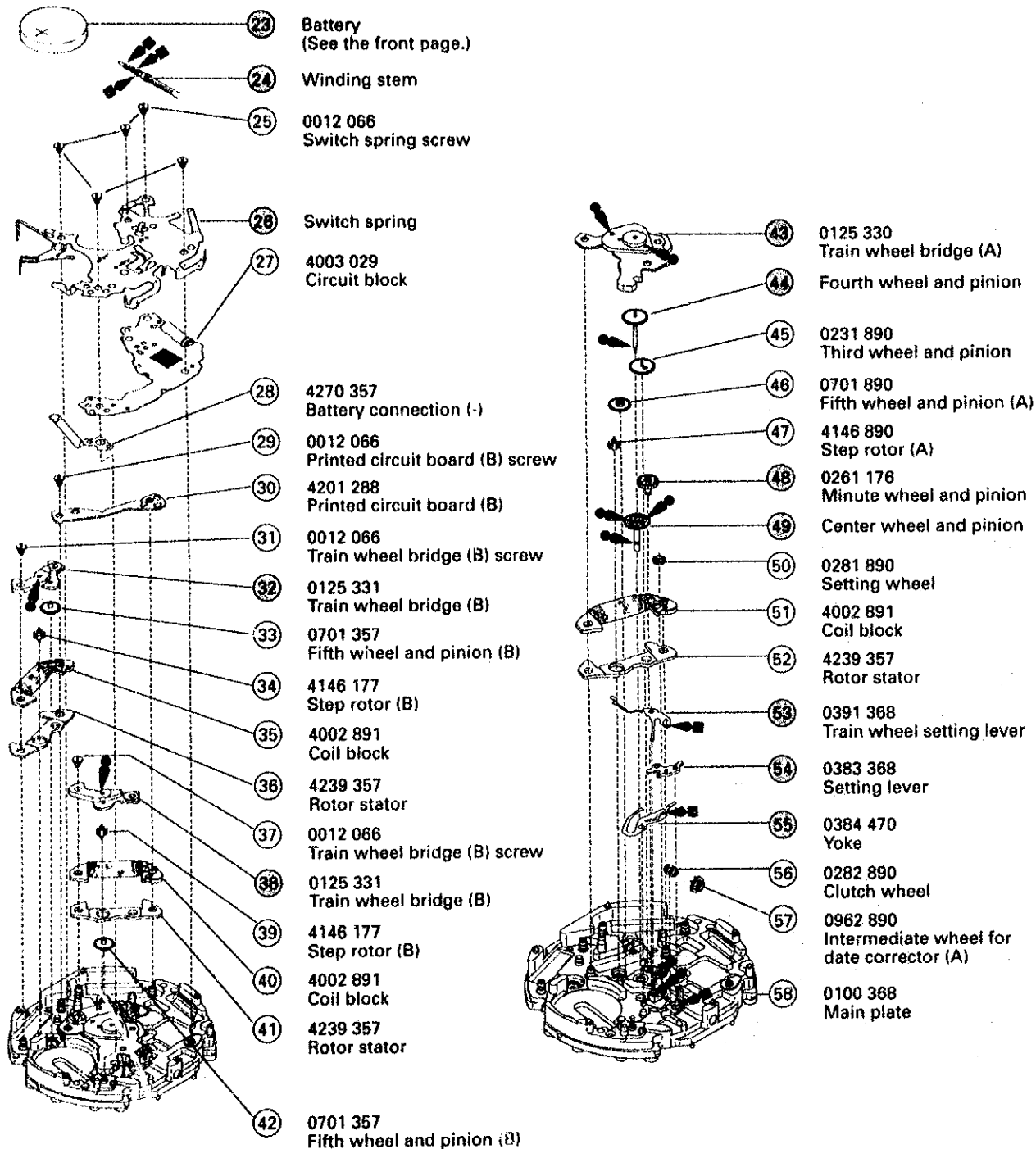
Cal. V657A

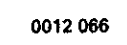

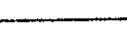
	• Auxiliary train wheel bridge screw (2 pcs.)
	• Switch spring screw (5 pcs.)
	• Train wheel bridge (B) screw (2 pcs.)
	• Printed circuit board (B) screw (1 pc.)

0012 066

 Please see the remarks on the following pages.

Remarks:

- 22 Hour wheel
- 44 Fourth wheel and pinion
- 49 Center wheel and pinion

Those parts specified above are determined based on the design of cases. Check the case number and refer to "CASING PARTS CATALOGUE" to choose a corresponding one.

• Discrimination of the hands installation height

Cal. V657A watch has numerals printed on the dial and movement to indicate the hands installation height. When repairing, refer to the table below.

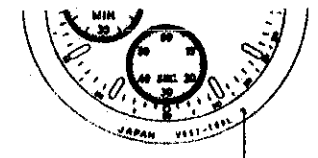
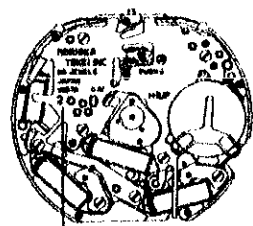
Discrimination	Height	Standard type	
		2	
	Printed on	Dial	Movement
Printed position			
		The numeral is printed on the extreme right.	The numeral is printed below the calibre number.

* Hands installation height can be discerned from the shape of the following parts. Refer to the table below.

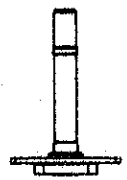
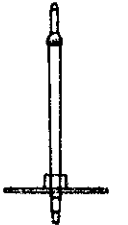
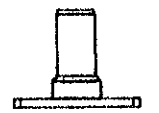
Numeral for discrimination	Center wheel and pinion	Fourth wheel and pinion	Hour wheel
2	 0221 368	 0241 407	 0271 407

24 Winding stem 0351 892

The type of winding stem is determined based on the design of cases. Check the case number and refer to "CASING PARTS CATALOGUE" to choose a corresponding winding stem.

26 Switch spring 4245 342

Use with the movement bearing the discrimination numeral "2".

TECHNICAL GUIDE

Cal. V657A

- The explanation here is only for the particular points of Cal. V657A.
- For the repairing, checking and measuring procedures, refer to the "TECHNICAL GUIDE, GENERAL INSTRUCTIONS".

I. STRUCTURE OF THE CIRCUIT BLOCK

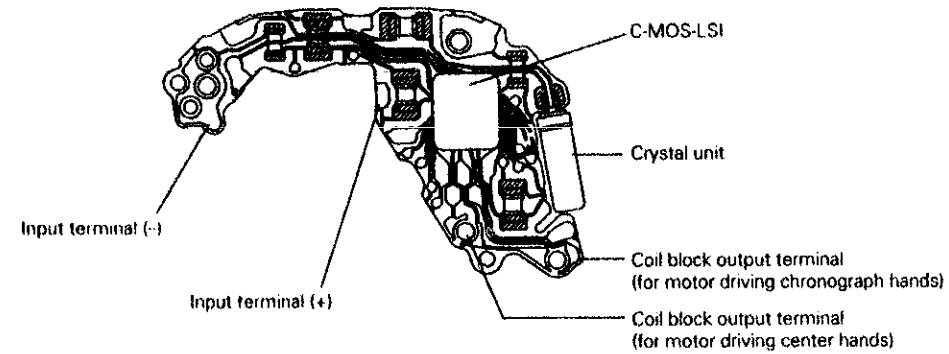

II. REMARKS ON INSTALLING THE BATTERY

- After the battery is replaced with a new one, or after the battery is re-installed following repairing procedures, be sure to short-circuit the AC terminal of the circuit block and the battery connection (+) with conductive tweezers to reset the circuit as shown in the illustration below. (When checking the current consumption, short-circuit with power supplied from an external source.)

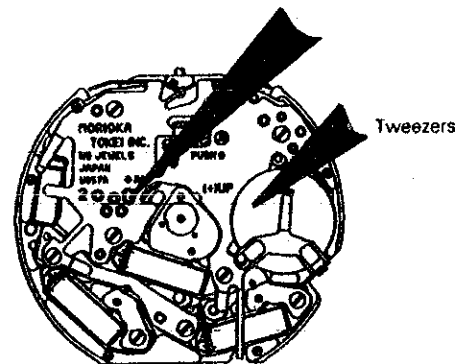

- The circuit can be reset with the complete watch. Follow the procedure below.

1. Pull out the crown to the second click.
2. Press buttons "A" and "B" at the same time for approximately 2 seconds.
 - * The chronograph second hand makes half a revolution counterclockwise and then returns to where it was. The chronograph 1/10 second hand makes a full revolution clockwise and stops.

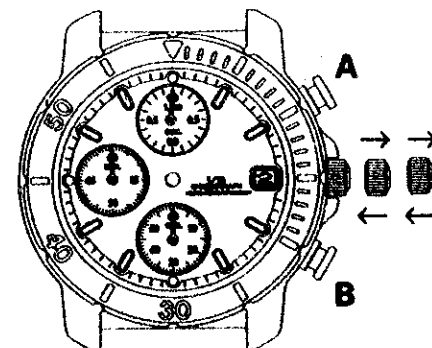

TECHNICAL GUIDE

Cal. V657A

3. Press button "A" repeatedly to reset the chronograph 1/10 second hand to the "0" position. Press button "B" repeatedly to reset the chronograph second and minute hands to the "0" position.
 - * The chronograph minute hand moves correspondingly with the chronograph second hand.
 - * The hands move quickly if the respective buttons are kept pressed.
4. Turn the crown to set the desired time and push the crown back in to the normal position.

III. REMARKS ON DISASSEMBLING AND REASSEMBLING

Use the universal movement holder for disassembling and reassembling.

- ① Hour, minute and second hands
- ② Chronograph minute, second and 1/10 second hands

Since a plastic main plate is used, place the movements on a flat metal plate or the like, and then install the hands at the position as specified below. Before doing so, check that the battery is installed in the movement.

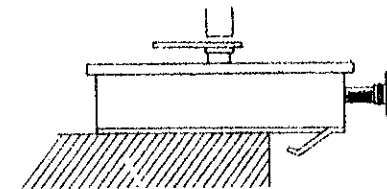

Hands to be installed	Positions at which hands are installed
Hour, minute and second hands	12 o'clock position
Chronograph 1/10 second hand	"0" position
Chronograph minute and second hands	60 minute/second position

- ③ Dial

Pry up the dial at the two recessed portions indicated in the illustration using a screwdriver.

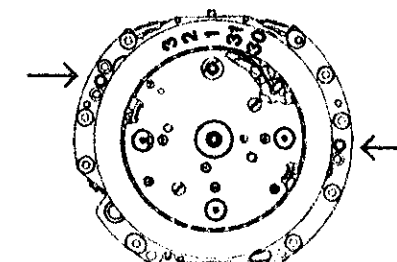





TECHNICAL GUIDE

Cal. V657A

7 Auxiliary train wheel bridge

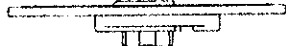
• Setting position (calendar mechanism)

8 0806 368 Date corrector wheel	13 0737 891 Intermediate wheel for date corrector (C)	10 0802 368 Date driving wheel	14 0962 891 Intermediate wheel for date corrector (B)
			

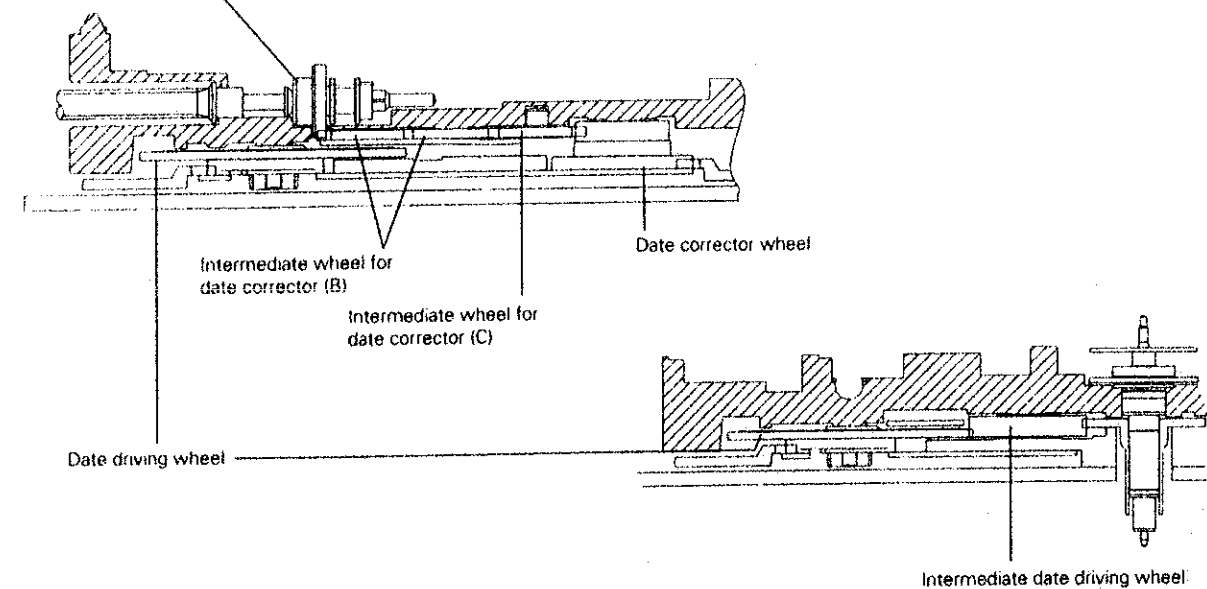
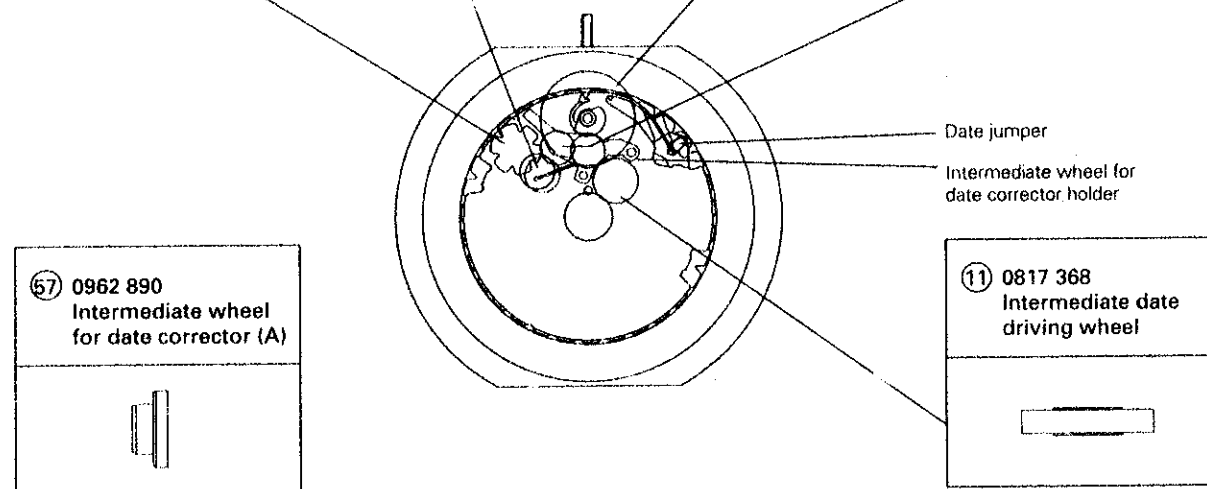



TECHNICAL GUIDE

Cal. V657A

7 Auxiliary train wheel bridge

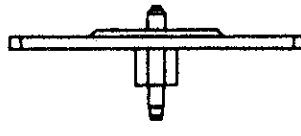
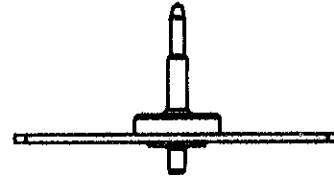
• Setting position (Stopwatch mechanism)

17 0886 002 Intermediate chronograph minute wheel and pinion (B)	18 0902 006 Chronograph minute wheel
	

19 0886 001 Intermediate chronograph minute wheel and pinion (A)

20 0885 357 Intermediate chronograph second wheel

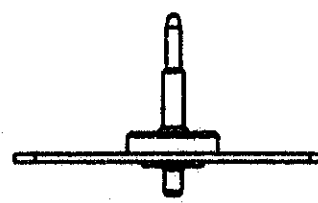
21 0888 006 Chronograph second wheel

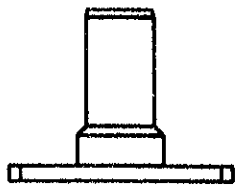
22 0271 407 Hour wheel

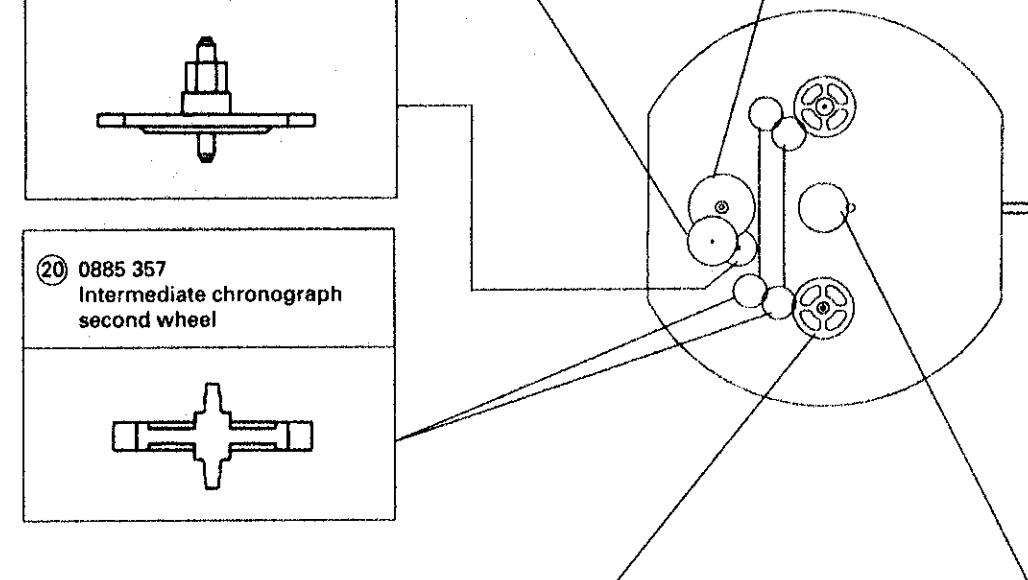

TECHNICAL GUIDE

Cal. V657A

23 Battery

• How to remove

Using tweezers, catch the protrusion of the switch spring indicated in the illustration below, and detach the hooking portion from the main plate. Then, remove the battery.

• How to install

Slip the battery sideways into the gap under the battery clamp of the switch spring. Then push the battery clamp so that the hooking portion catches the main plate securely.

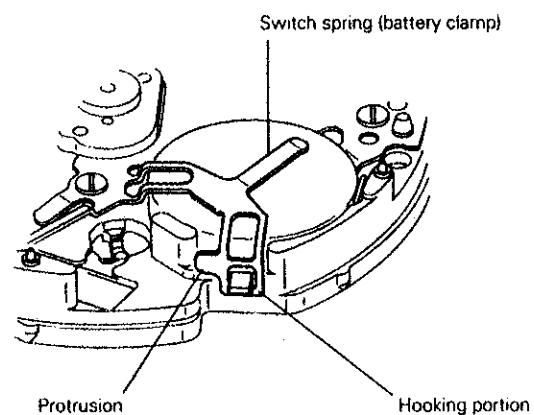

24 Winding stem

• How to remove

Remove the winding stem with the crown at the normal position while pushing the setting lever (marked with "PUSH").

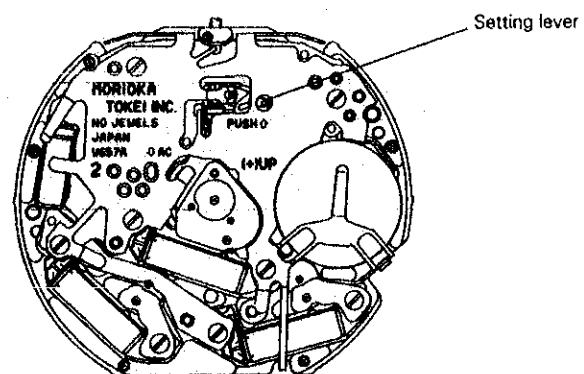

TECHNICAL GUIDE

Cal. V657A

43 Train wheel bridge (A)

32 38 Train wheel bridge (B)

• Setting position

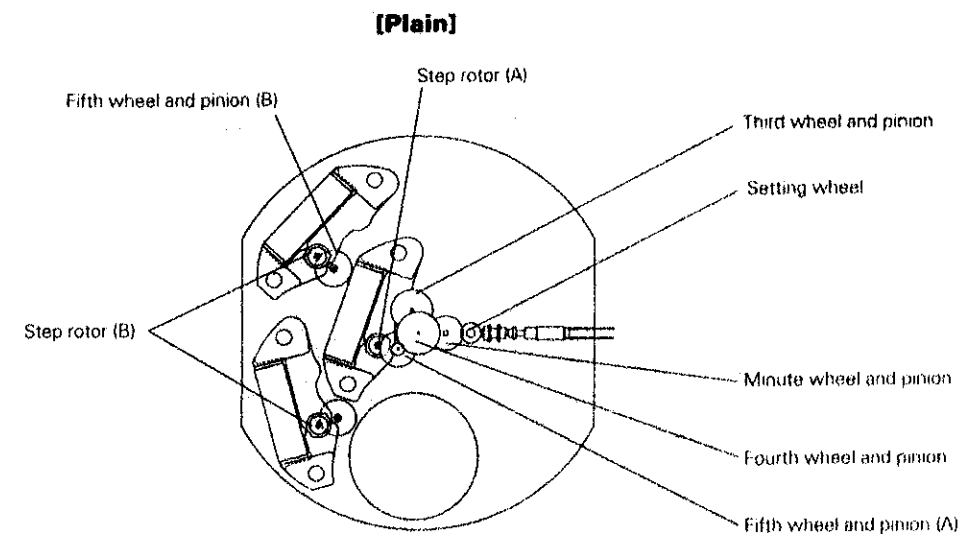

[Cross section]

Train wheel bridge (A)

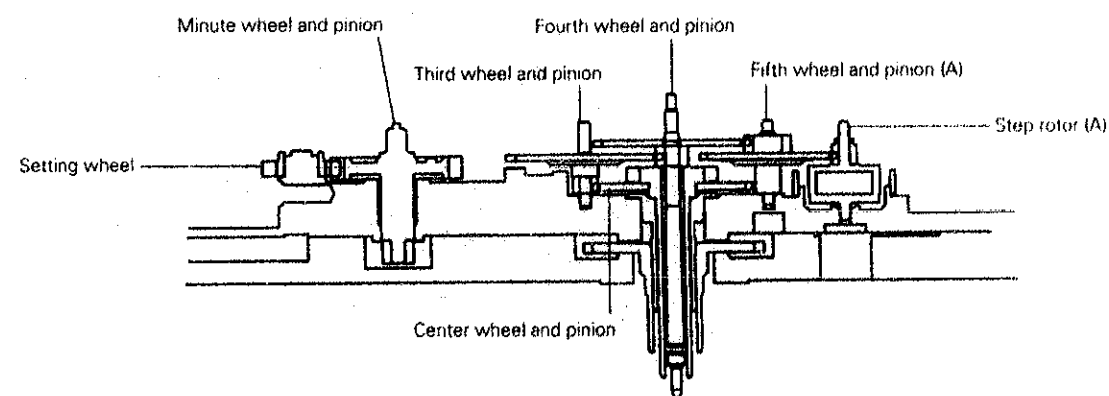

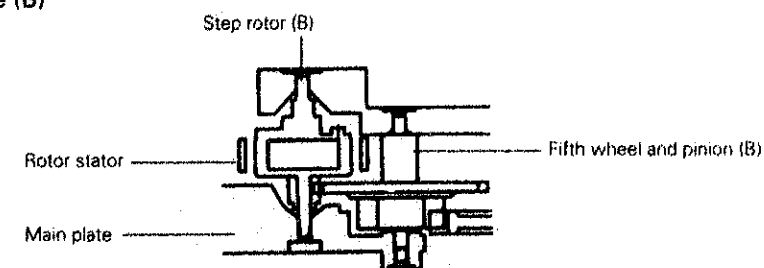

Train wheel bridge (B)



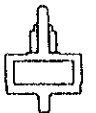

TECHNICAL GUIDE

Cal. V657A

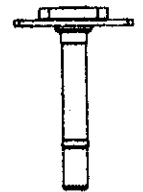
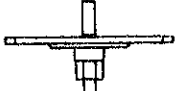
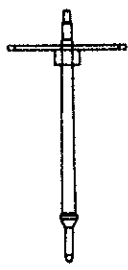
• Distinction of wheels

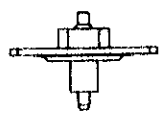
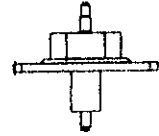
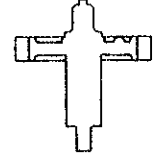
Parts	Step rotor (A)	Step rotor (B)	Center wheel and pinion	Third wheel and pinion	Fourth wheel and pinion
Shape					
Parts No.	4146 890	4146 177	0221 368	0231 890	0241 407

Parts	Fifth wheel and pinion (A)	Fifth wheel and pinion (B)	Minute wheel and pinion	Setting wheel
Shape				
Parts No.	0701 890	0701 357	0261 176	0281 890

Remarks:

Reassemble the step rotor (B) with its pinion facing the main plate side.

TECHNICAL GUIDE

Cal. V657A

- ⑤3 Train wheel setting lever
- ⑤4 Setting lever
- ⑤5 Yoke

• Setting position

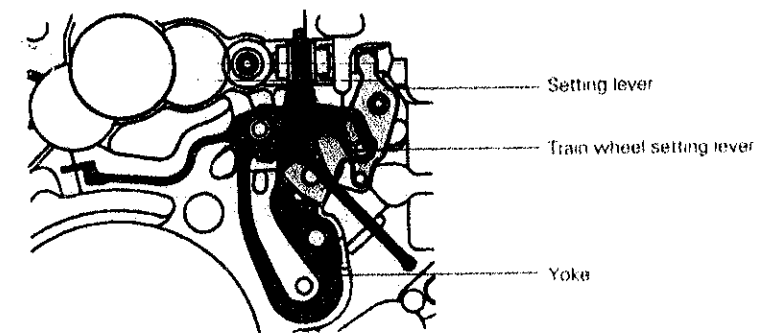

Remarks:

Check that the contact spring of the yoke is not deformed.

IV. VALUE CHECKING

• Coil block resistance

1.9KΩ ~ 2.3KΩ

• Measuring time accuracy

When measuring time accuracy, make sure that the stopwatch is stopped. Otherwise, correct accuracy cannot be obtained.

• Current consumption

For the whole movement : Less than 3.0μA
For the circuit block alone : Less than 1.5μA

Remarks:

Before measuring the current consumption, short-circuit the AC terminal of the circuit block and battery connection (+) with conductive tweezers.