

# GRS **TOOLS** System 3

## Introduction

The System 3 is a precision power tool with an internal air piston that gives a controlled “hammering” action. This produces an effective source of impact power for hand engraving, stone setting, carving, texturing and many other uses. The System 3 is smooth and responsive which allows the operator to work with precision and ease. Heat-treated stainless steel alloys are used in all major parts for low maintenance and durability.

A specially designed foot control (patent pending) is an important part of the System 3. As the operator pushes down on the foot control, the internal hammering gently starts and then becomes increasingly more powerful with more foot pressure. This allows a smooth beginning with fine control. This is a major difference between the System 3 and other, less refined tools.

## Instructions For:

004-781 & 004-780 System 3  
004-760 System 3 Handpiece  
004-771 System 3 Foot Control



## Precision Air Tool for:

- Stone Setting
- Texturing
- Carving
- Hammering
- Engraving
- and more...

**\*\* IMPORTANT \*\***

## MUST READ

**THE SYSTEM 3 WILL NOT OPERATE AS SHIPPED.**

A SPRING HAS BEEN REMOVED FROM INSIDE THE HANDPIECE. THE USER MUST FIRST SELECT A SPRING FOR THE TYPE OF WORK DESIRED. THE PROPER SPRING IS VERY IMPORTANT.

IT MAKES A BIG DIFFERENCE IN POWER AND CONTROL.

READ THESE INSTRUCTIONS THOROUGHLY FOR MORE INFORMATION.

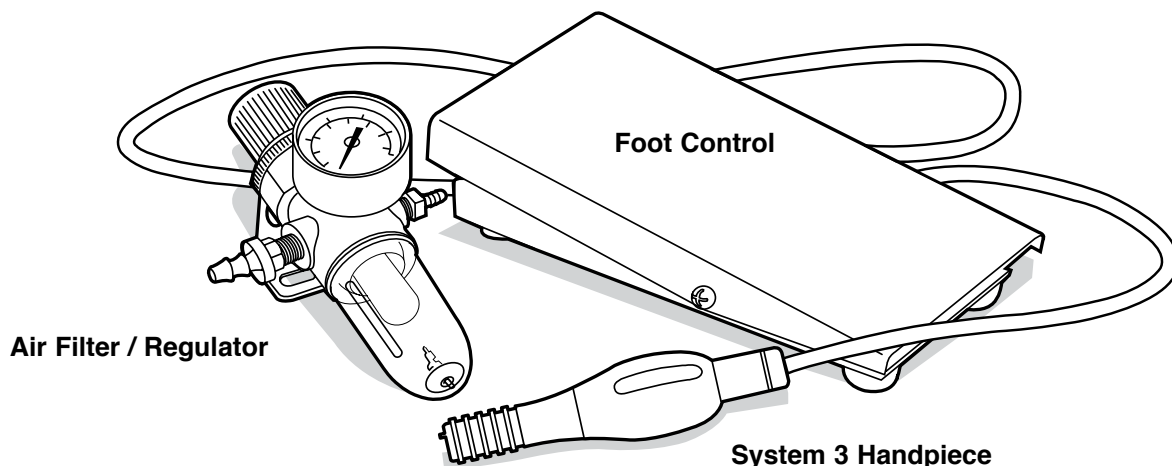

# Installation

The System 3 comes as a complete kit with handpiece, foot control, and air filter/regulator, or major components may be purchased separately. The first installation step is to connect the System 3 to compressed air.

## AIR CONNECTION

### With System 3 Air Regulator

*Note: Connecting the System 3 to an existing air compressor may require parts from a Hardware store such as air hose, fittings, or clamps, or an Automotive Parts store that handles air tools, paint sprayers, etc). Because of the wide variety of air hoses and fittings, there is no standard connection that fits everyone's air compressor.*

Each System 3 requires compressed air with at least 50 psi (3,4 bar) pressure and 0.7 SCFM (20 liters/min) flow capacity. Since the System 3 air regulator can reduce air pressure, up to 120 psi (8,3 bar) air may be supplied to the regulator. In some special cases, as little as 20 psi (1,4 bar) air pressure is enough for limited fine work only. Having a minimum of 50 psi (3,4 bar) available ensures a broad range of power. However, more than 50 psi (3,4 bar) will provide little or no increase in impact power.

Locate the air filter/regulator within easy reach of the System 3 operator. A good location is the edge of a workbench. The compressed air supply line (A) should be connected to the air filter/regulator. The inlet is a 1/8" NPT (pipe thread) hole on the left side of the regulator when looking directly at the air pressure gauge. Two barb fittings are included with the System 3 filter/regulator. Install the barb that best fits your air compressor hose. An air hose with inside diameter of 0.170" to 0.250" (4 to 6mm) will work fine. Now, attach the air supply hose and secure with a hose clamp.

The right side of the air filter/regulator has a factory-installed barb fitting. Attach the long hose (B) from the foot control to this fitting using a wire hose clamp (included) over the hose. Last, push the System 3 handpiece hose onto the small hose coupler (C) on front of the foot control. Wetting the coupler with water will help.

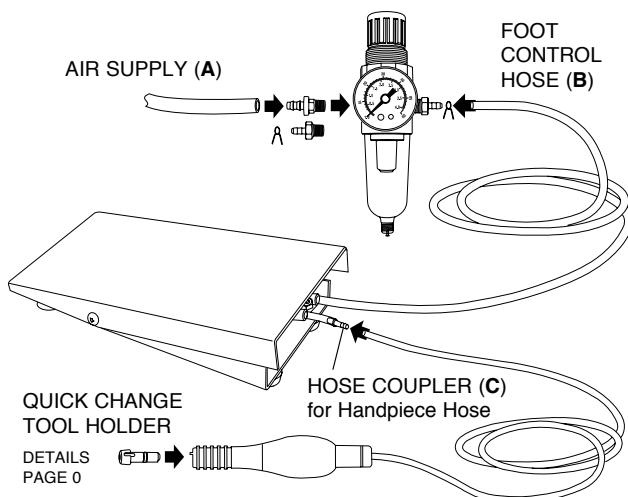

### Without System 3 Air Regulator

The System 3 handpiece and foot control may be used without the System 3 air filter/regulator. It may be connected to most any commercial filter/regulator capable of 20-60 psi (1,4 — 4,1 bar) air regulation. In production shops, the System 3 may be connected directly to a source of regulated air that is preset to the desired operating pressure. For both of these cases, connect the long air hose (B) from the foot control to the regulated air source (A). Then, connect the handpiece hose to the small hose coupler (C) on the front of the foot control. Remember, for the greatest versatility, each operator should be able to individually regulate the incoming air pressure to "fine tune" the System 3 to their work. However, in a continuous and repetitive production environment, multiple System 3's can be installed on a major air line that is preset to an average air pressure. This simplifies larger installations and saves money by eliminating individual filter/regulators.

*NOTE: The System 3 Handpiece may also be operated without the System 3 Foot Control using 20-60 psi (1,4-4,1 bar) compressed air and a simple on/off air valve. However, the System 3 Foot Control (patent pending) is more sophisticated than a simple air valve. It continually senses air pressure and automatically adjusts an internal flow valve for precise power control. Operating the System 3 Handpiece without the System 3 Foot Control will result in less precise control of impact power.*

## HANDPIECE SPRING

### Selection & Installation

Before using the System 3 Handpiece a spring must be selected and installed. As previously mentioned, the System 3 will NOT work as received. The user must realize there is a choice of handpiece springs which dramatically alter the characteristics and power of the System 3. The System 3 comes standard with three springs (Heavy, Fine & Very Fine) and a LIGHT PISTON. To increase the System 3's capabilities even more, an optional HEAVY PISTON (#004-391) is also available. Use the charts (AT RIGHT) as a guide to help you select the right combination of piston and spring for the work you want to do.

The following is a brief description of the springs to help you understand their function.

- **Heavy Spring** - (1.71"/43mm)

It is for medium to heavy engraving, stone setting and hammering. The stronger spring needs more air pressure, usually 30-50 psi (2,1-3,4 bar).

- **Fine Spring** - (1.45"/37mm)

This spring is for medium to fine work. Using the finer springs, the handpiece starts more gently and is much more controllable. The fine spring needs only 15-35 psi (1,0-2,4 bar).

- **Extra Fine Spring** - (1.31"/33mm)

It is the shortest spring is for very fine work. Used for very fine work and is very controllable. Needing only 5-15 psi (0.4-1.0 bar).

Try each spring on a variety of work. If one of the finer springs give enough power and does the job, use it because you will have better control. If more power is needed, simply switch to the stronger spring and readjust the air pressure. If even more power is needed switch to the optional heavy piston.

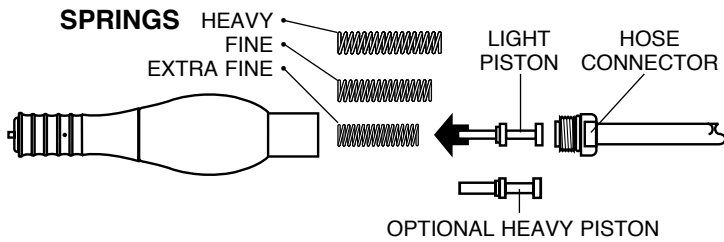

To install a handpiece spring, unscrew the hose connector at the rear end of the handpiece. Remove the piston (it should simply fall out of the handpiece bore). Put the desired spring into the handpiece bore. Now reinstall the piston with the SMALL END FIRST! Screw the hose connector back on the handpiece. The System 3 handpiece is now ready to use.

Remember, if a wide variety of work needs to be done, changing springs from one job to the next may offer significant performance advantages.

## PISTON / SPRING / AIR PRESSURE CHARTS

### LIGHT PISTON 004-351

**HS** HEAVY SPRING - 1.71" (43mm) long

**FS** FINE SPRING - 1.45" (37mm) long

**EFS** EXTRA FINE SPRING - 1.31" (33mm) long

NOTE: EXTRA FINE SPRING NOT RECOMMENDED TO USE WITH MODEL #004-775 HAMMER HANDPIECE

80					5.4
70				<b>HS</b>	4.7
60					60
50			<b>FS</b> ...	<b>HS</b>	3.4
40			<b>EFS</b>		40
30			<b>HS</b>		1.4
20	<b>FS</b>				20
10	<b>EFS</b>				10
0					0
PSI	VERY LIGHT	LIGHT	MED.	HEAVY	VERY HEAVY
<b>TEXTURING / HAMMERING</b>					

### HEAVY PISTON 004-391(OPTIONAL)

**HS** HEAVY SPRING - 1.71" (43mm) long

NOT RECOMMENDED TO USE FINE OR VERY FINE SPRING WITH HEAVY PISTON

80					5.4
70				<b>HS</b>	4.7
60					60
50				<b>HS</b>	3.4
40					40
30			<b>HS</b>		1.4
20					20
10					10
0					0
PSI	VERY LIGHT	LIGHT	MED.	HEAVY	VERY HEAVY
<b>TEXTURING / HAMMERING</b>					

## TOOL BITS & QC TOOL HOLDERS

The System 3 uses a patented tool holding system that is unique to GRS handpieces. Instead of putting the tool directly in the handpiece, the tool is first mounted in a Quick Change (QC) tool holder. The holders are precisely machined to fit into the end of the handpiece. They allow tool changes in less than 3 seconds without using a wrench, turning a knob, or pushing a lever. The operator simply pulls the tool (with its tool holder) straight out of the handpiece.

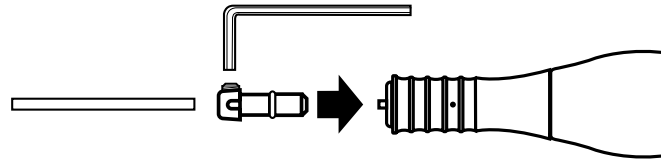

To mount a tool bit, insert the tool into the hole of the Quick Change tool holder and tighten the set screw. Notice there is a small slot milled in the top of each tool holder. This slot mates with a post that extends from the front of the System 3 handpiece. Try to orient all tools the same way in each holder. If the tool shank is too big, grind it as needed on a bench grinder. The shank does not have to fit perfectly. Should the tool loosen repeatedly in use, grind a small flat spot on the tool shank where the set screw makes contact.

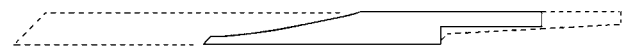

Modify standard gravers as shown.

Standard hand gravers must be shortened or they will be too long to use comfortably. Some traditional hand tools are long enough to make two tools! When shortening or modifying tools and gravers, do not over-heat the tool while grinding. (If the tool turns brown, blue or purple, it has been over-heated). Use frequent water cooling and lots of patience . . . don't hurry. For more convenience and a higher grade of tool, use GlenSteel .094" square HSS tool blanks and .080 square carbide tool blanks available from GRS and GRS distributors.

The Quick Change tool holders are held in the handpiece by friction between the tool holder's rubber O-ring and the handpiece receiver bore. If the tool holders get hard to remove, put a small amount of light grease on a tool holder and insert it into the handpiece. This transfers a thin grease film to the handpiece receiver bore and greatly reduces the tool holder friction.

The Quick Change tool holders fit a variety of GRS equipment in addition to the System 3 handpiece. A calibrated sharpening fixture accepts all Quick Change tools allowing accurate sharpening without removing tools from their holders. A comfortable rubber-coated hand graver handle is also available for handwork using Quick Change tools. Contact a GRS tool distributor or GRS for more information.

GRS Power Hone, Diamond Wheels And Dual Angle Sharpening Fixture

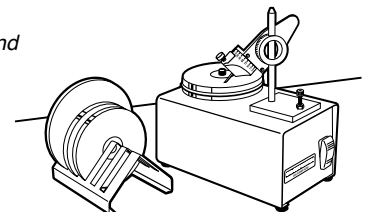

# Operation

If the following steps have not been completed, refer to the appropriate instructions before continuing.

1. Connect it to a source of compressed air.
2. Select and install the handpiece spring.
3. Prepare and mount the tools in the Quick Change holders.

*NOTE: If the above steps have not been completed, DO NOT proceed.*

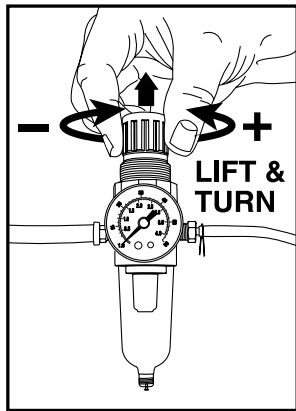

Begin by adjusting the air pressure to about 40 psi (2,8 bar). Holding the handpiece in the air, push down rapidly on the foot control. The handpiece should start operating with a definite hammer action. Remove foot pressure from the foot control. The handpiece should stop. Experiment with the foot control. More foot pressure should provide more impact power. Because the System 3 is an air oscillator, it needs an initial "start-up" rush

of air. The special foot control provides most of this start-up air control. There are some factors which can cause start-up problems for the System 3 handpiece.

1. Always return the foot control to the full "OFF" position after each cut. Do not stop the handpiece without completely removing foot pressure. Do not keep the foot pedal partially depressed between cuts. This is essential for predictable and consistent starting of the handpiece.
2. Do not move the foot pedal too slowly during the start-up of each cut. A smooth, definite foot action is all that is required. However, no foot stomping is necessary, either!
3. The operator's foot should be centered over the foot pedal. Use the whole foot in a rocking motion, not just the toes or heel.

The foot control will soon become easy to manage throughout the whole power range. But remember, the System 3 foot control is NOT just on/off. It allows the operator to smoothly vary power from light to heavy as needed while cutting or hammering. Novice users often forget to coordinate the foot control once the handpiece is started. In the beginning, be especially aware of using the foot control continuously throughout the cut. The goal is coordinating the foot, hand, and eye automatically, like driving an automobile. At that point, the user can simply do the job with outstanding ease and accuracy.

The air pressure setting is an important variable. The right pressure will depend on the job being done. The user should simply experiment to determine what works best. More air pressure will provide greater power up to a point. Try not to use more pressure than needed. This wastes energy and makes the tool needlessly hard to control. Changing the supply air pressure, handpiece spring and piston size not only changes handpiece power, but also affects the foot control response.

Be aware of this when experimenting with air pressure and handpiece springs. Use the PISTON / SPRING / AIR PRESSURE CHARTS on page 00 as a guide to assist you.

## HOLDING THE HANDPIECE

### Engraving & Hammering

It is most important to place the tool properly on the work BEFORE starting the handpiece. Attempting to enter a cut or position a hammer point with the power ON (handpiece stroking) can quickly dull tools or ruin the work!

#### A Special Note To Jewelers & Stone Setters About Hammering.

The System 3 is not like hammer handpieces for flexible-shaft motors. When operating the System 3, first put the hammer tool firmly on the work and hold it down to keep the tool from bouncing. Only AFTER placing the hammer tool on the metal should the power be applied. Then, smoothly slide the hammer tip along the work allowing it to hammer and burnish as it goes. Again, do NOT let it bounce and do NOT start hammering in the air then try to bring the stroking tool in contact with the work. If operated properly, the System 3 will move metal faster, provide a finer hammer finish, and be less likely to damage stones than any flexible shaft hammer! But, these advantages will NOT be realized if the operator tries to use the System 3 like a flexible-shaft hammer handpiece!

When engraving or carving, hold the handpiece overhand, like a table knife, NOT a pencil. The index finger may rest lightly on the top of the tool. To start a cut, first position the tool on the work and THEN apply power gradually with the foot control. Use slight (this really means slight) forward pressure to keep the tool point moving smoothly through the cut. The depth of cut is controlled by a combination of tool angle and the right downward pressure. When tool sharpening is correct, the downward pressure should only be slight even when cutting deep lines. If excessive downward pressure is needed, the tool isn't properly sharpened.

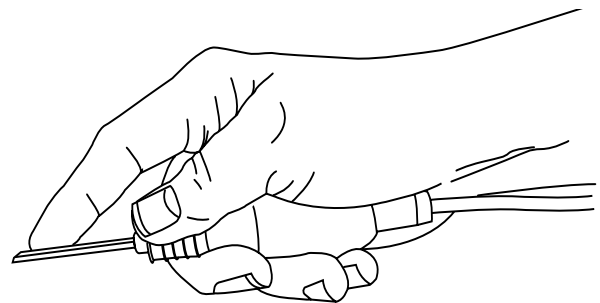

The correct angle to hold the tool while engraving or carving is controlled by tool geometry and sharpening. Raising the hand up or down will change the tool to workpiece angle. Finding the angle that works best is part of the learning process. Like most hand engraving, there is a fine line between digging into the work and coming out of the cut. Once again, most problems are caused by improper tool selection and sharpening.

## NOTE ON TOOL SHARPENING

These instructions do not include a thorough and accurate discussion of tool selection and sharpening. There are many uses for the System 3. This makes it almost impossible to discuss the number of tools as would have to be addressed. The System 3 is only a source of power. The basics of tool sharpening remain virtually the same regardless of whether the source of power is the hand alone, chasing hammer or the System 3 power tool.

Hold the work in a rotating engraver's vise, BenchMate or other sturdy, maneuverable work holding system. Hand holding the work usually creates fatigue and awkwardness. Avoid using a stationary bench vise because most work needs to be moved continuously for best results.

GRS Magnablock™

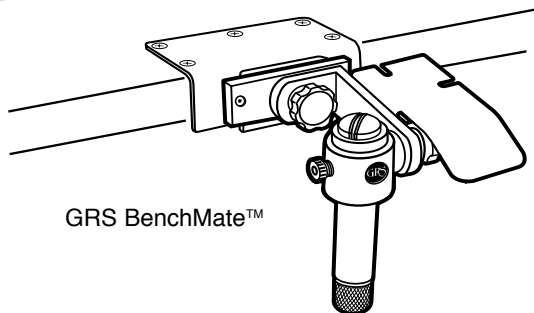
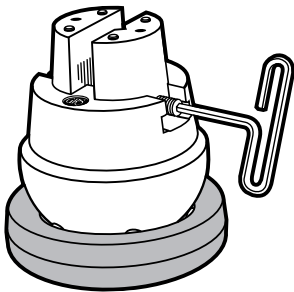

GRS BenchMate™

# Maintenance

## HANDPIECE CLEANING

The System 3 handpiece requires little maintenance. Keeping the internal piston and bore clean is important. If these internal parts get too dirty, the handpiece can work erratically especially at the start. This internal dirt will also accelerate wear which shortens the life of the System 3 handpiece.

To clean, unscrew the handpiece hose connector and remove the piston and spring. If the inside bore appears dirty, also remove the tool receiver assembly. This is the front portion of the handpiece that accepts the Quick Change tool holders. A good way to unscrew the receiver assembly is to put a tool holder with a strong square or rectangular tool into the handpiece. Then, grip the tool (not the tool holder) with a wrench or pliers and unscrew the entire receiver assembly. Next, unscrew the large handpiece knob and remove it from the end of the handpiece body.

Clean the disassembled handpiece body, piston, and spring with a non-greasy solvent (that evaporates entirely without a residue). Soap and hot water may also be used if the parts are rinsed thoroughly and dried completely after washing.

### HANDPIECE KNOB

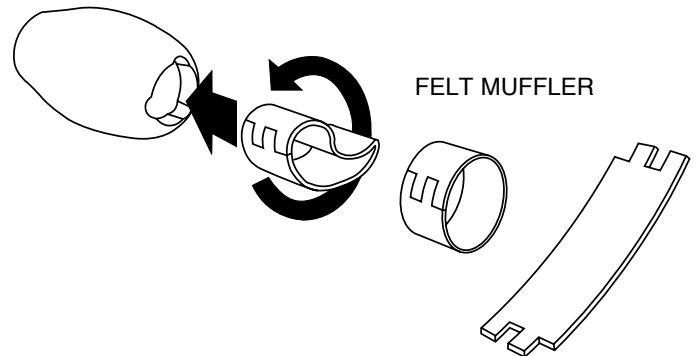

While the handpiece knob is removed, reach inside the knob with a small tool or pencil and remove the felt muffler element from the recessed area inside the knob. If dirty, clean the element by washing or blowing with compressed air. To reinstall the muffler element, fold it carefully making sure the notched fingers interlock. Carefully insert the folded element back inside the knob. Using a small tool or pencil, open the muffler element and work it back neatly into the recessed area inside the knob.

*NOTE: Some compressed air is contaminated with rust, excessive water, oil residue, dirt, etc. The System 3 handpiece is quite durable and will tolerate many imperfect air supplies. However, exceptionally bad air can cause malfunction and even ruin the System 3 and other air tools as well. The System 3 filter/regulator will remove a reasonable amount of contaminants. Some exceptionally bad air supplies may need additional treatment of the air before it enters the System 3 filter/regulator.*

## HANDPIECE LUBRICATION

The System 3 handpiece should be lubricated about every 8 hours and always after cleaning. Use the dry powder lubricant provided with the handpiece or other similar dry lubricant (available at hardware stores).

To lubricate, remove the hose connector and piston. Squirt a small amount of dry lube inside the handpiece bore. Reinstall the piston (small end first) and squirt a small amount of dry lubricant on top of the piston. Replace the hose connector and test the handpiece.

For a short time after lubricating, the handpiece may stroke differently until the lubricant becomes evenly distributed.

If another dry lubricant is used, the handpiece may also work differently, especially at the beginning of a cut. Don't over-lubricate! Too much lube can cause erratic handpiece operation. If this happens, clean the handpiece and relube.

## FOOT CONTROL

After extensive use, the foot control pivot bushings, pivot arm and plunger bar need a small amount of grease. Using a small brush or swab, apply a light, general purpose grease to these areas.

## AIR FILTER/REGULATOR

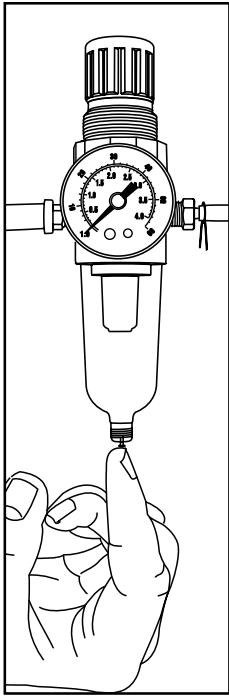

The System 3 filter regulator has an internal filter to remove any solid particles greater than 5 micron. This element is NOT designed to remove oil. The filter housing and bowl are also designed to trap excess water. Any excess water will collect at the bottom of the clear plastic bowl. It should be drained regularly by pressing up on the drain valve stem located on the bottom of the filter bowl. Compressed air pressure will then blow any water from the bowl. To keep water and sediment contained, put a rag under the bowl before pushing the drain valve stem.

If the filter element appears dirty, unscrew the clear plastic drain bowl and clean or replace the element. The element unscrews for easy cleaning and replacement. When reinstalling the drain bowl, be sure the rubber O-ring seal is in proper position or it will leak air.

## SYSTEM 3 PARTS

Replacement parts are available from any GRS distributor, or directly from GRS Tools, a division of Glendo Corporation. When ordering, please include part number, description, quantity, and indicate that the parts are for the System 3.

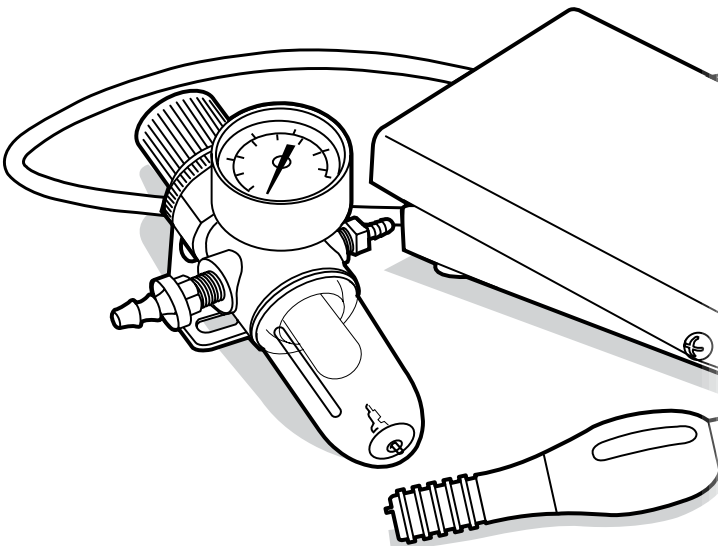

# System 3

Item	Part No.	Description
------	----------	-------------

### Handpiece Parts List

	004-760	System 3 Handpiece (complete assembly)
1.	004-353	Receiver
2.	002-084	O-Ring (2 required)
3.	022-065	O-Ring (2 required)
4.	022-071	Spiral Pin
5.	004-352	Anvil
6.	004-355	Handpiece Body
7.	004-375	Spring (EXTRA FINE)
8.	004-370	Spring (FINE)
9.	004-365	Spring (HEAVY)
10.	004-351	Piston
11.	004-391	Piston (HEAVY) - OPTIONAL
12.	002-759	O-Ring 1/2" X 5/8" X 1/16"
13.	004-354	Knob
14.	004-356	Muffler Element
15.	004-366	Hose Retainer
16.	004-367	Hose Connector
17.	050-026	Handpiece Tubing (6 ft/183cm required)
**	022-100	Dry Lubricant (for handpiece)
18.	004-368	Foam Grip

### Quick Change Tool Holder Parts List

	004-804	Complete Tool Holder (Package of 3)
19.	002-950	Set Screw, #8-32 X 1/8"
20.	022-029	O-Ring
21.	002-605	Hex Wrench, 5/64"

### Foot Control Parts List

	004-771	System 3 Foot Control (complete assembly)
22.	004-358	Foot Control Base
23.	002-036	Rubber Foot (1 required)
24.	011-210	Rubber Foot Assembly (3 required)
25.	002-289	Machine Screw, #8-32 X 3/4" (2 required)
26.	002-583	Cable Clamp (2 required)
27.	002-064	Hex Nut, #8-32
28.	050-002	1/4" O.D. Urethane Tubing (10 ft / 3m Required)
29.	050-026	Handpiece Tubing ( 6 in/15cm required)
30.	022-083	Tube Coupler, 3/32"
31.	004-359	Valve Bracket
32.	004-360	Pivot Bracket
33.	004-361	Pivot Arm
34.	002-292	Machine Screw, #8-32 X 5/8" flat head
35.	004-363	Plunger Bar
36.	022-001	Cap Screw, #8-32 X 1/2" socket head
37.	002-104	Kep Nut, #8-32
38.	022-096	Air Control Valve
39.	022-081	Barb Fitting, #10-32 X 3/32"
40.	022-080	Barb Fitting, #10-32 X 5/32"
41.	004-364	Spring
42.	022-091	Spring Guide
43.	002-766	Hose Clamp
44.	004-344	Foot Control Top
45.	022-070	Bushing (2 required)
46.	002-065	Machine Screw, #10-32 X 3/8" (2 required)
47.	002-061	Machine Screw, #8-32 X 3/8" (2 required)
48.	002-568	Machine Screw, #8-32 X 1/4"
49.	002-992	Machine Screw, #10-32 X 3/4"
50.	002-109	Hex Nut, #10-32

### Filter / Regulator Parts List

	004-762	System 3 Filter/Regulator (complete assembly)
51.	002-364	Filter Element, 5 micron
52.	002-417	Drain Bowl Assembly
53.	002-615	Gauge
54.	002-517	Barb Fitting, 1/8 NPT X .170
55.	002-361	Barb Fitting, 1/8 NPT X 1/4"
56.	002-766	Wire Hose Clamp

**SYSTEM 3 HANDPIECE**  
004-760 COMPLETE ASSEMBLY

# System 3

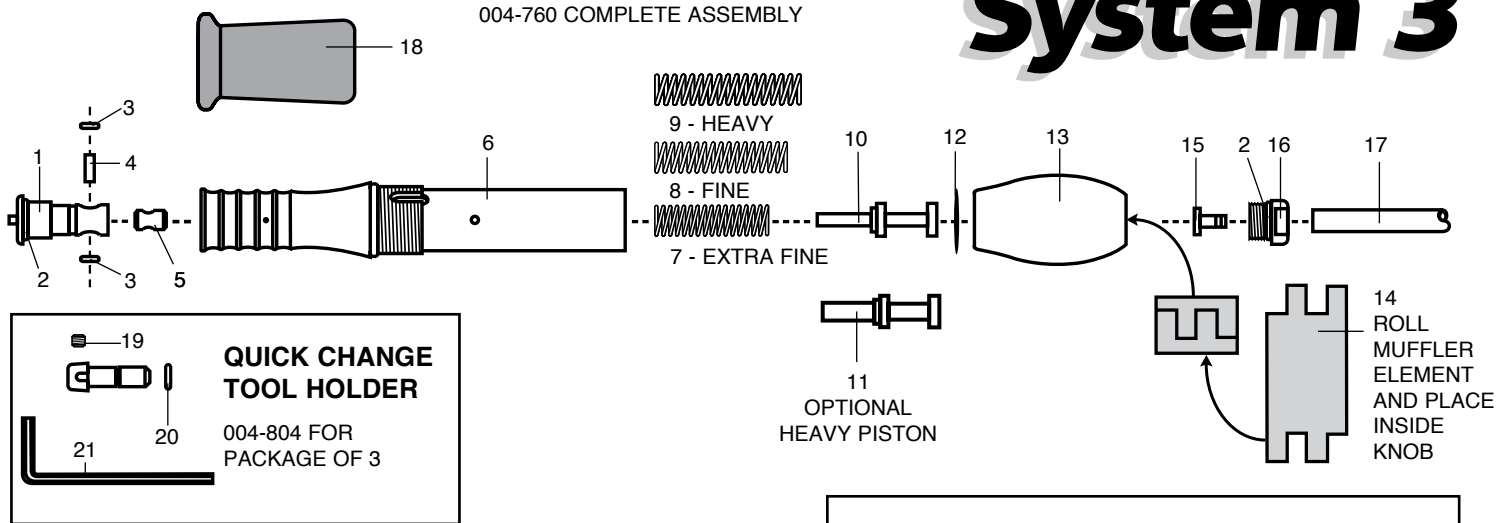

**SYSTEM 3  
FOOT CONTROL**  
004-771 COMPLETE ASSEMBLY

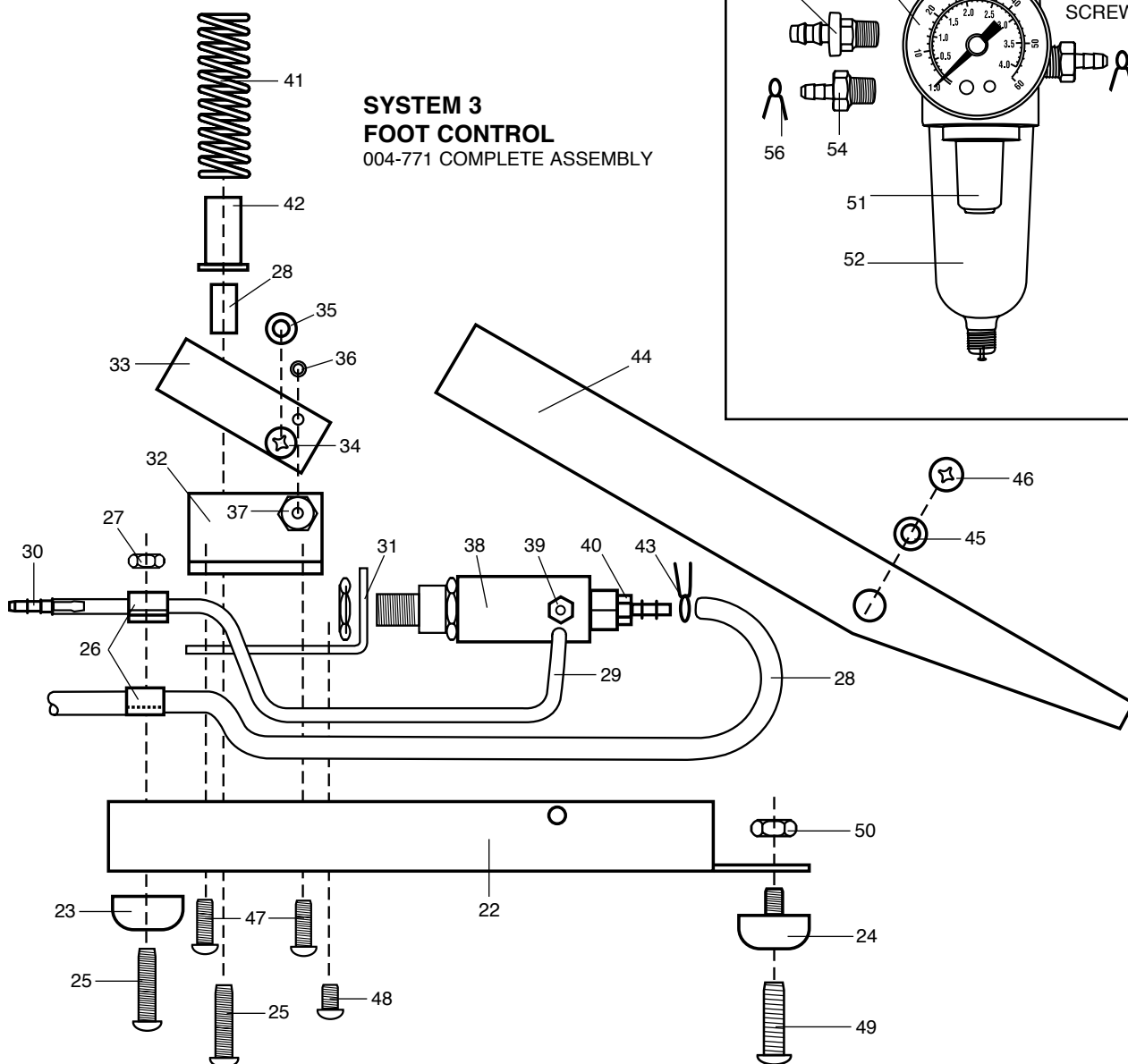
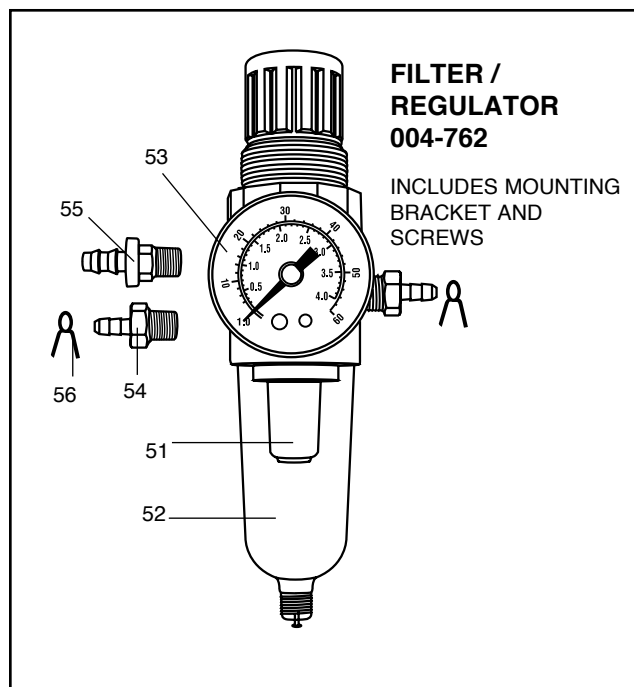

# Important

---

The System 3 has an internal oscillating piston. As it hammers, this piston creates some vibration.

Although the handpiece is designed to reduce the vibration transmitted to the hand, working with any tool of this type exposes the operator to vibration. A few people are more sensitive to vibration levels than others. Should the user experience hand or finger numbing, excessive tingling, pain, etc., the use of this tool should be discontinued. There are many variables that affect this and several steps can be taken to reduce the effect of this vibration.

## TIPS TO LESSEN HAND FATIGUE AND VIBRATION

---

1. Hold the System 3 handpiece as loosely as possible. Studies done on a variety of power tools indicate that strong tool gripping significantly aggravates hand vibration problems.

2. Keep hands warm. Cold fingers and hands can be more susceptible to adverse effects of vibration.

3. Use only as much power as you need and apply the power smoothly with your foot. Some operators apply excessive power with the foot control and then try to "hold back" the tool with their hand. In this case the operator's hand must absorb the excess power that isn't needed to do the work!

4. Maintain sharp and accurate tools. Using the correct tool that is properly sharpened can significantly reduce the power needed to work. When a lot of metal must be moved by hammering, use a smaller nose tool to concentrate the hammer power.

When engraving or cutting metal, pay close attention to proper tool geometry and sharpness. A properly prepared tool will "stay in the cut" with little or no hand force. If the tool must be pushed forward or downward excessively, then something is probably wrong with the tool or work technique!

5. Let the System 3 do the work! Many handworkers were trained using hand power alone which often involves strong hand gripping and pushing forces.

Even after they switch to a power tool such as the System 3, many of these traditional handworkers continue to strongly grip and push out of habit.

Although it is difficult to break these work habits, the unnecessary, strong gripping and pushing actually reduce the effectiveness of the System 3 while increasing hand vibration. The operator loses two ways.

The preceding information on hand vibration is to inform the operator about certain physical aspects of using power hand tools including the System 3. Like the warnings on common items used everyday, this information is intended to educate and not unnecessarily frighten the operator from enjoying the benefits of this new tool. It should be noted that many people use power tools such as the System 3 to actually reduce the wear and tear on their hands and arms while working!

---

## FOR MORE INFORMATION

Contact Glendo Corporation / GRS Tools anytime Monday - Friday, 8 am - 5 pm CST to speak with a one of our friendly representatives.

System 3 is a trademark of Glendo Corporation. All rights reserved. © 2008 Glendo Corporation. LIT 011-249.



Gebrüder Boley GmbH & Co. KG  
Julius-Hölder-Str. 32  
D- 70597 Stuttgart

Phone: +49 (0) 711 - 13271-0  
Fax: +49 (0) 711 - 13271-90  
E-mail: [info@boley.de](mailto:info@boley.de)  
[www.boley.de](http://www.boley.de)