

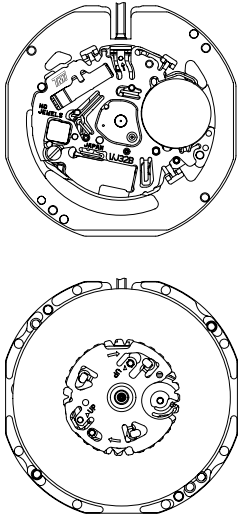

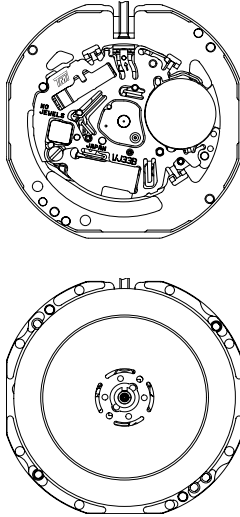
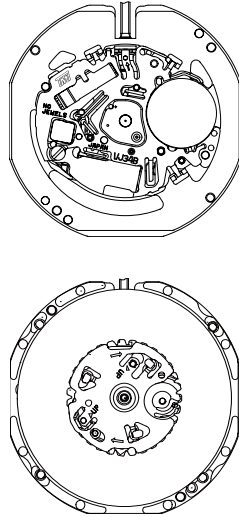

TECHNICAL GUIDE
&
PARTS CATALOGUE

Cal.VJ3 Series
(VJ32B/33B/34B)

ANALOGUE QUARTZ



Cal. No.		VJ32B	VJ33B	VJ34B
Item				
Movement size	Outside diameter	$\phi 23.70$ mm 22.60 mm : between 12 o'clock and 6 o'clock sides 22.60 mm : between 3 o'clock and 9 o'clock sides		
	Casing diameter	$\phi 23.30$ mm 22.10 mm : between 12 o'clock and 6 o'clock sides 21.40 mm : between 3 o'clock and 9 o'clock sides		
	Total height	2.71 mm (including the battery)	2.94 mm (including the battery)	2.71 mm (including the battery)
Time indication		3 Hands Calendar	3 Hands Day & Date Calendar	2 Hands Calendar
Driving system		Step motor (Load compensated driving pulse system type)		
Additional mechanism		Electronic circuit reset switch Second setting device Date setting	Electronic circuit reset switch Second setting device Date setting Day setting	Electronic circuit reset switch Date setting
Antimagnetic		≥ 1600 A/m		
Loss/Gain (Monthly rate)		Less than ± 20 seconds at normal temperature range		
Frequency of crystal oscillator		32,768 Hz		
Operational temperature range		- 5 °C ~ + 50 °C		
Regulation system		Nil		
Measuring gate by quartz tester		Use 10 second gate * Set the winding stem with crown at the normal position		
Battery		SR621SW (Silver oxide battery) Battery life is approximately 3 years		
Jewels		0 Jewel		

Disassembling procedures Figs. ① → ③③	Lubricating : Types of oil	 A3a / Moebius 9010
		 A2a / Moebius 9030
Reassembling procedures Figs. ③③ → ①	Oil quantity	 Normal quantity

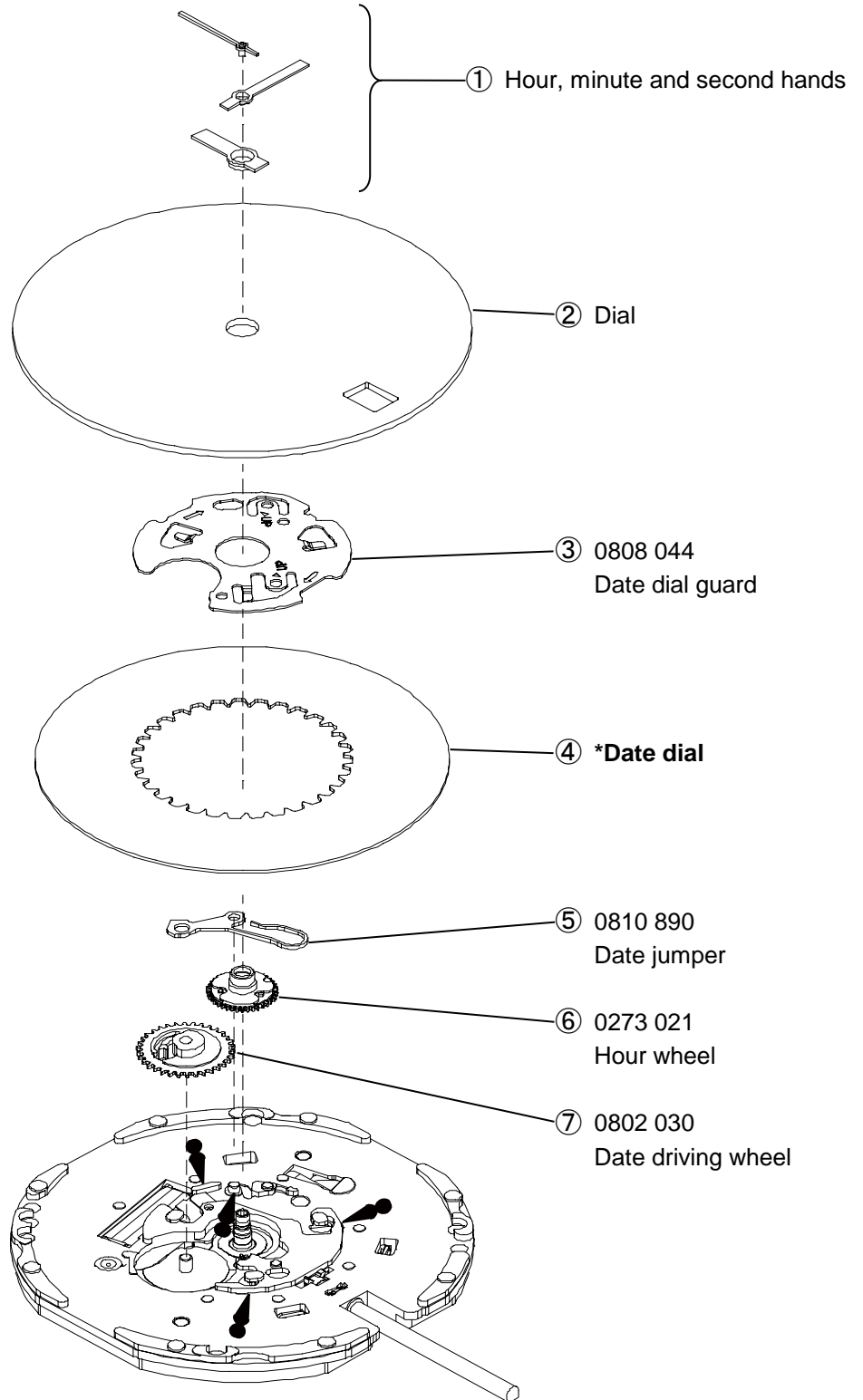
<<VJ32B/34B>>





*Refer to page 5 for each parts code

Disassembling procedures Figs. ① → ③③	Lubricating : Types of oil	 A3a / Moebius 9010
		 A2a / Moebius 9030
Reassembling procedures Figs. ③③ → ①	Oil quantity	 Normal quantity

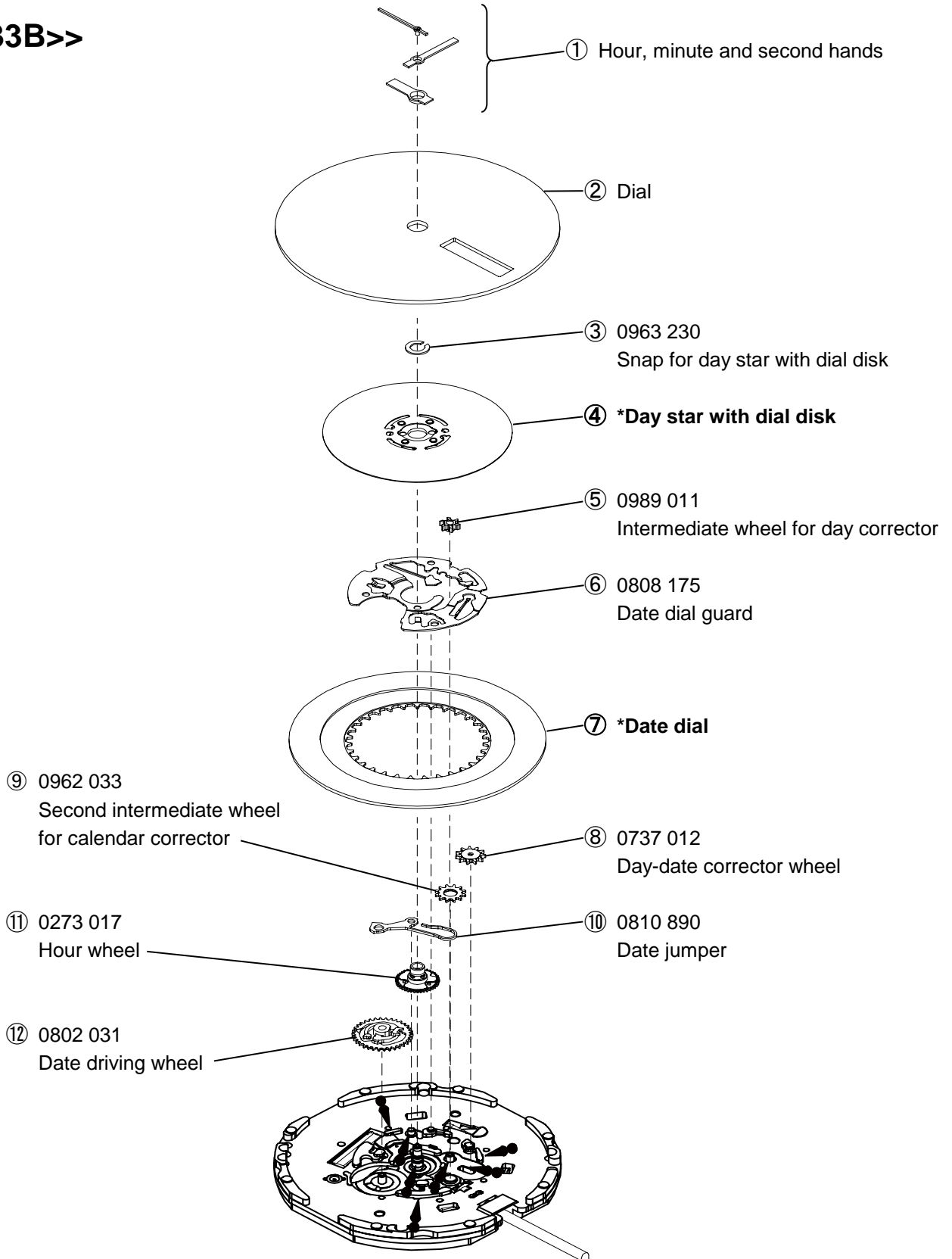
<<VJ33B>>



*Refer to page 5 for each parts code

Disassembling procedures Figs. ① → ③③	Lubricating : Types of oil
Reassembling procedures Figs. ③③ → ①	 A3a / Moebius 9010  A2a / Moebius 9030
	Oil quantity  Normal quantity

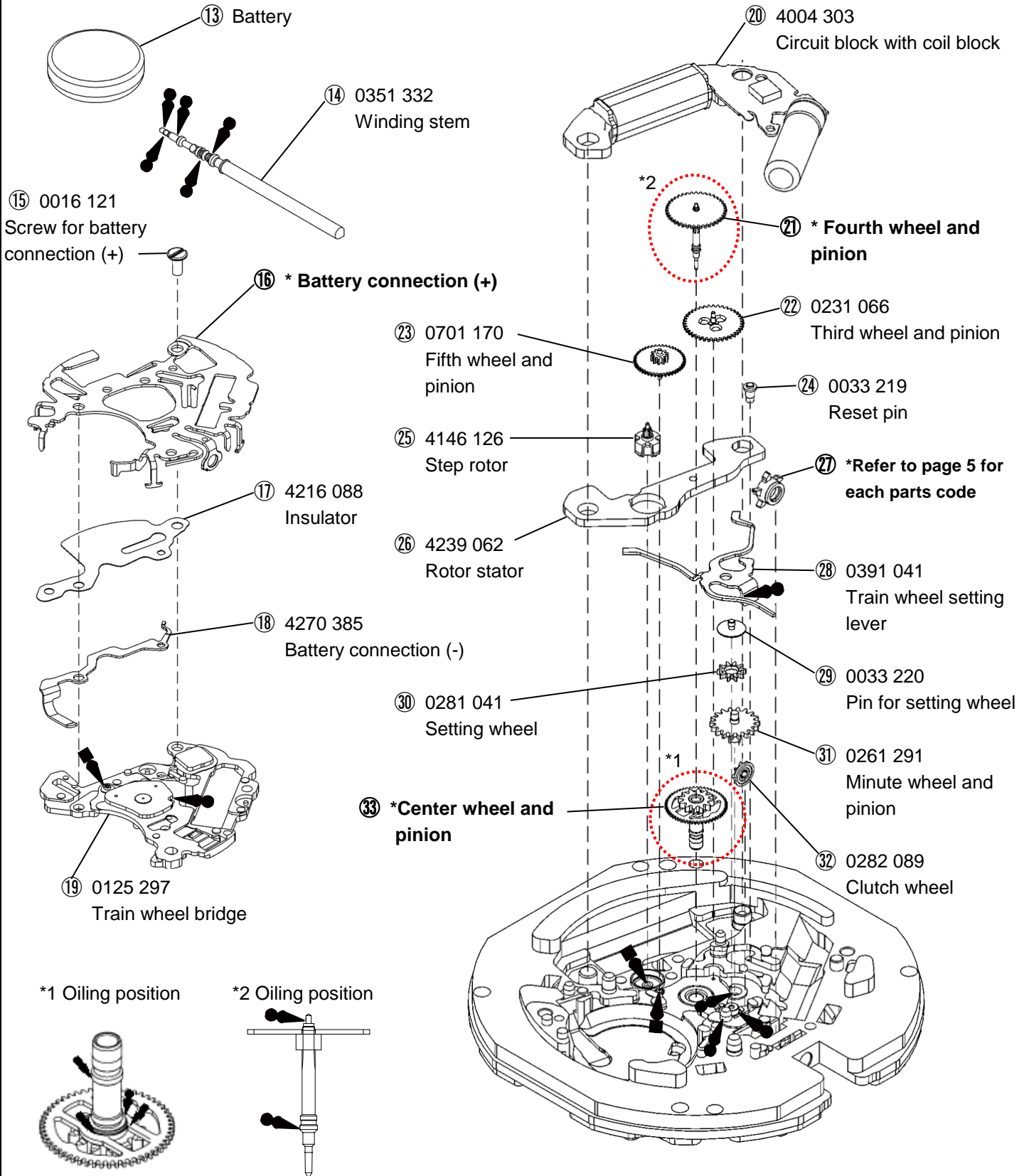

*Refer to page 5 for each parts code

Remarks:

○ Date dial

<VJ32B/34B>

Part code	Positing of crown	Positing of date frame	Color of figure	Color of background
0878 153	3H	3H	Black	White
0878 157	3H	3H	White	Black
0878 158	3H	6H	Black	White
0878 159	3H	6H	White	Black

<VJ33B>

Part code	Positing of crown	Positing of date frame	Color of figure	Color of background
0878 170	3H	3H	Black	White

○ Day star with dial disk

<VJ33B>

Part code	Positing of crown	Positing of date frame	Color of figure	Color of background	Language
0150 005	3H	3H	MON~SAT:Black SUN :Red	White	English & Spanish

○ Different parts for each CAL.

Parts name	VJ32B	VJ33B	VJ34B
Date corrector wheel	0806 142	—	0806 142
⑳ First intermediate wheel for calendar corrector	—	0962 009	—
㉑ Center wheel and pinion	0221 055	0221 061	0221 055

○ The part which is not common in Cal.VJ32B/VJ33B/VJ34B

Parts name	VJ32B	VJ33B	VJ34B
㉒ Battery connection(+)	4268 049	4268 052	4268 054
㉓ Fourth wheel and pinion	0144 097	0144 102	0144 088

***All parts code are subject to change without notice.**

The explanation here is only for the particular points of Cal.VJ32B /VJ33B/ VJ34B

I .STRUCTURE OF THE CIRCUIT BLOCK

Notes: Since the circuit block and coil block are made by one piece, in disassembling and reassembling take care not to cut the coil line.

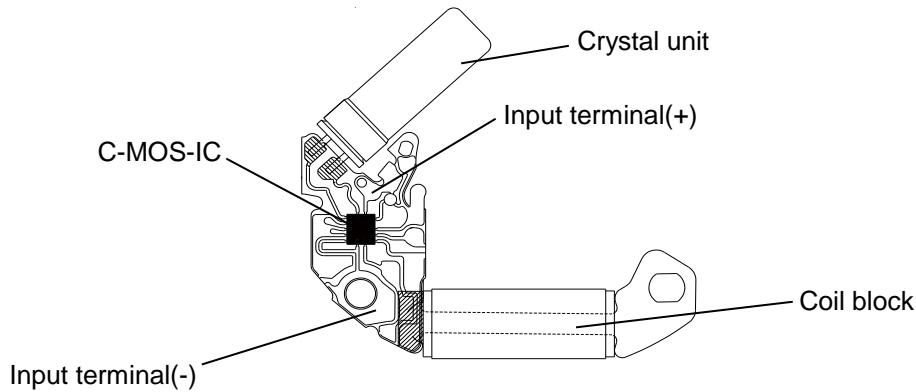

II . REMARKS ON DISASSEMBLING AND REASSEMBLING

① Hands

•How to install

Place the movement directly on a flat metal plate or the like to install the hands.

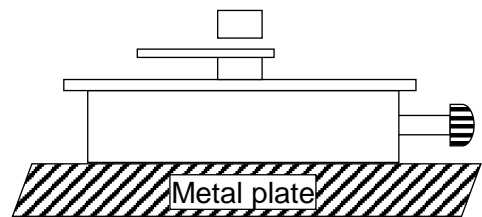

② Intermediate wheel for day corrector

Set the intermediate wheel for day corrector in the direction as shown in the illustration at right.

*Cal.VJ32B/VJ34B not Intermediate wheel for day corrector.

Dial side

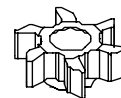

Main plate side

③ Date dial guard

The date dial guard has three protrusions to be caught under the main plate, and it is also fixed by two guide pins.

•How to remove

- 1) Lightly lift the A portion of the date dial guard with tweezers to release it from the guide pin, and then move it in the clockwise direction until it gets off the guide pin.
- 2) Release the B portion of the date dial guard in the same way as described above, and then move it in the clockwise direction until gets off the guide pin.
- 3) Check that all the three protrusions of the date dial guard have come off from the main plate, and then remove the date dial guard.

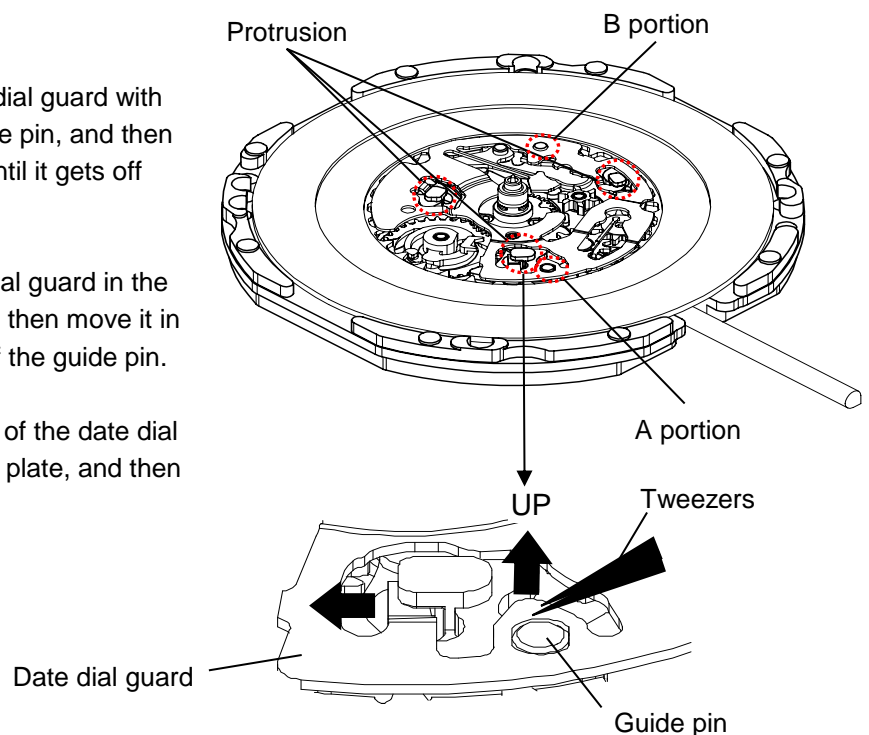

•How to install

- 1) Put the date dial guard on the main plate so that the A and B portion are over the guide pins, as shown in the illustration at right.
- 2) Move the protrusion D of the date dial guard in the counterclockwise direction so that it is caught under the main plate.
- 3) Slightly move the protrusions C and E in the counterclockwise direction alternately to set them under the main plate. Then, set the A and B portions of the date dial guard to the guide pins.
- 4) Check that the date dial guard is fixed securely to the main plate.

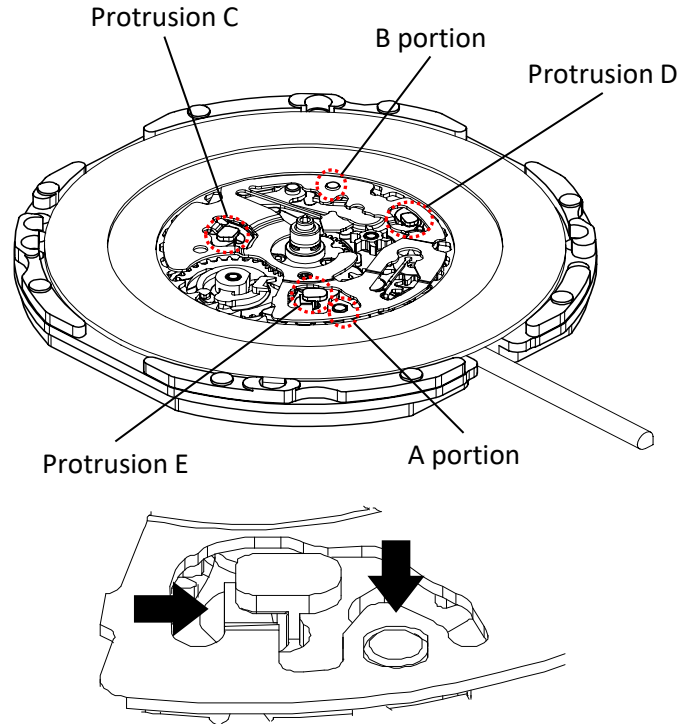

④ Battery

•How to install battery

Insert the battery aslant in the direction shown by the arrow.
Check the battery connection (+) securely touches the side face of the battery.

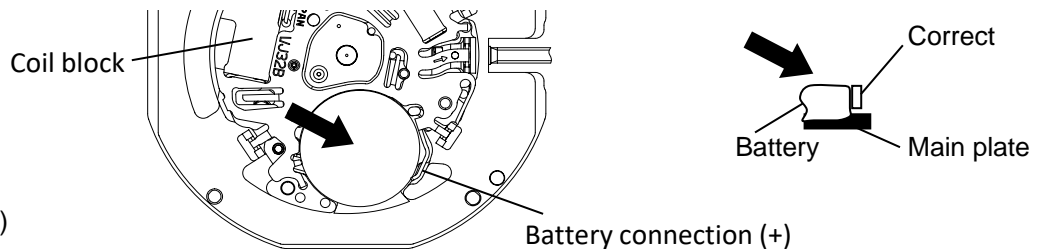

⑤ Battery connection (+)

•How to install

Have the hook portions (3 places) catch the main plate (Fig.1 & Fig.2).
In disassembling and reassembling, take care not to deform the hook portion.
After installing the battery connection (+), check that the three hook portions securely catch the main plate.

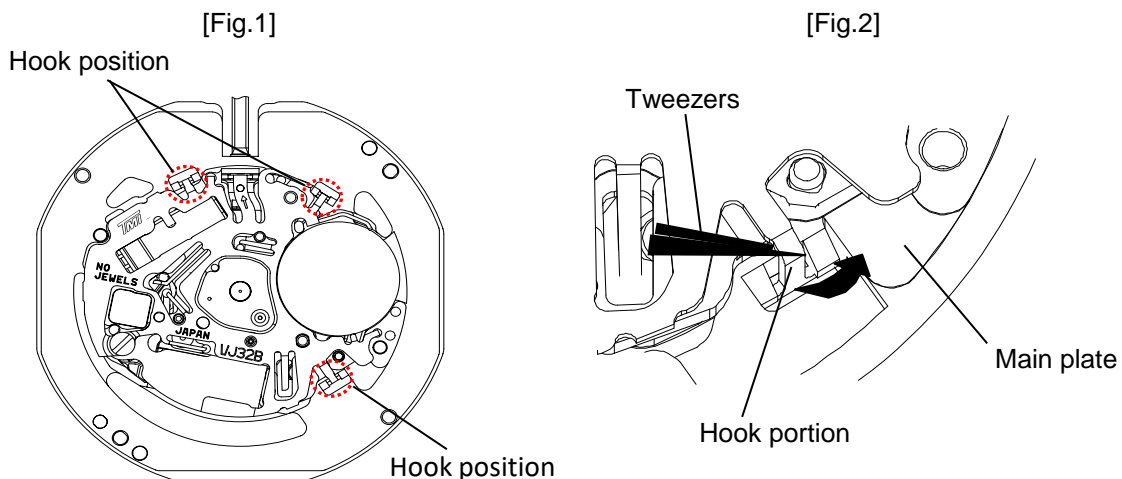

⑥ Insulator
•Setting position

Notes: To Insulate between the battery connection (+) and the battery connection (-), Insulator should be put at the three pin securely as bellow.

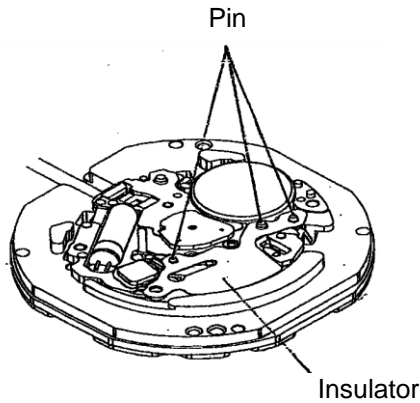

⑦ Train wheel bridge
•Setting position

Notes: Since the fifth wheel and pinion and step rotor are made of plastics, take care not to damage them in disassembling and reassembling.

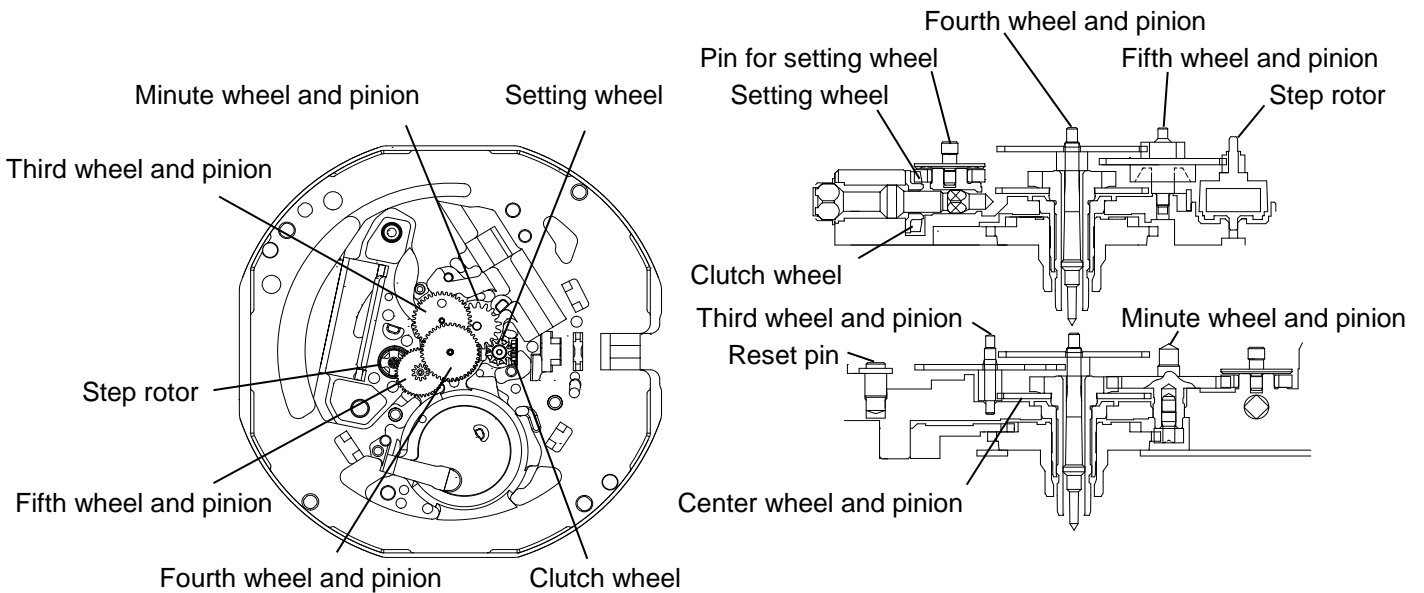

⑧ Train wheel setting lever
•Setting position

Notes:
•Catch the part of spring of the Train wheel setting lever to the pin like as below.
•Take care not to deform the spring portion of the Train wheel setting lever.

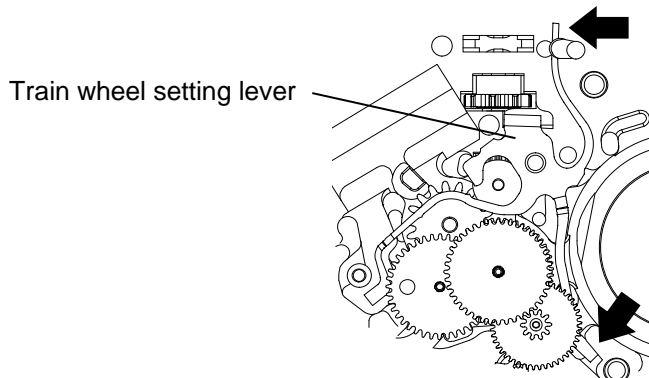

⑨ Pin for setting wheel

Notes:

• In disassembling and reassembling, take care not to damage the portion that is assembled of the pin.
(Since the portion that is assembled of the pin is made of plastics and easily damaged.)

• In disassembling,
pick the pin up main plate to vertical direction with care.

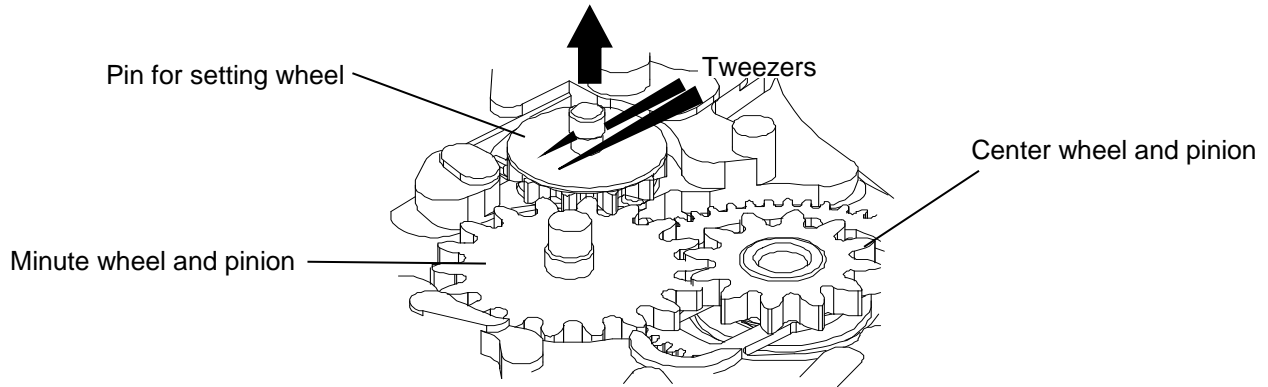

• In reassembling,
push the pin in main plate to vertical direction with care.

