

Die genauen Masse der verschiedenen Pendellängen usw. sind aus der Pendelliste zu entnehmen

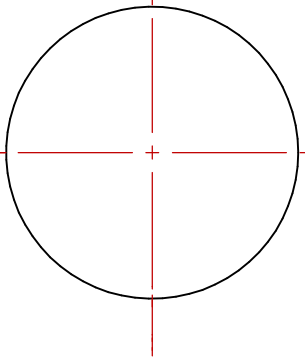

zur Information

Gehwerkgewicht: 2,1Kg
Schlagwerkgewicht: 2,1Kg

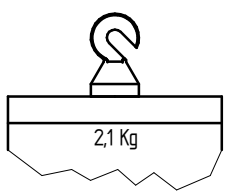
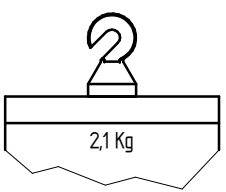
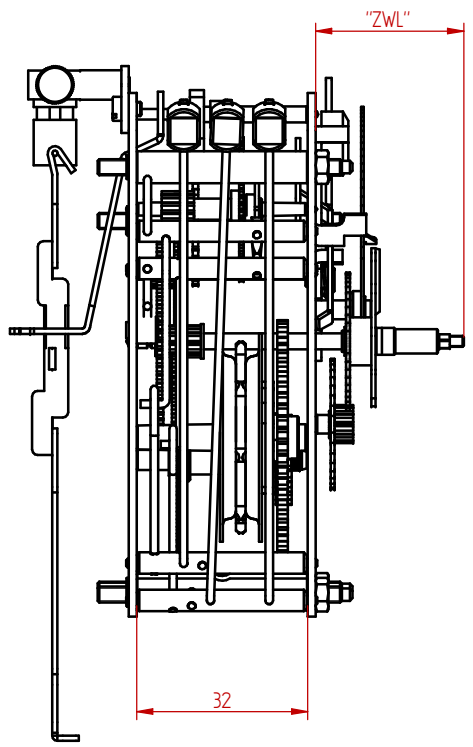

"ZWL" = Zeigerwerkslänge
length of centershaft

- W0241-030 = 33,1 mm
- W0241-033 = 53,1 mm
- W0241-031 = 27,6 mm

Hermle Werk
W0241-030

8 Tage 1/2 Stundenschlagwerk; Kettenzug; Grahamgang; Hämmer seitlich; bim bam Gongschlag

8 day movement with 1/2 hour strike; weight driven; dead beat escapement; side hammers; bim bam gong strike

 <small>78559 Gosheim</small>		Masse ohne Toleranzangabe DIN 2768 f	Werkstück- kanten DIN 6784	Maßstab : 1:1	Gew.: 0,000 kg
		Datum	Name	Einbauzeichnung	
Bear.	23.10.2017	HMetzger			
Gepr.					
Norm					
				W0241-030	Blatt 1 von 1
Zust.	Anderung	Datum	Nam.		