



**Before any use of the device, each user must have read the operating instructions and must pay particular attention to the safety instructions.**



**Before its first use, the Natator 125 must be purged (see the chapter "Before first use" within the Operating instructions).**

## Testing a watch

### Increasing the pressure

- A.** Turn the knurled ring and completely unscrew the hand (A').



**Do not force the hand wheel once it is fully screwed out.**

- B.** Place the watch in the basket.
- C.** Place the basket in the tank.
- D.** Fill the tank.
- E.** Close the lid, pivot and screw in the locking handle while pressing the purge push-button (E').
- F.** Turn the knurled ring and increase the pressure using the hand wheel (F').



*If the force to be applied to the hand wheel is too large, the handle may be positioned as indicated in the adjoining figure. The pressure can then be increased or reduced by back and forth motion.*

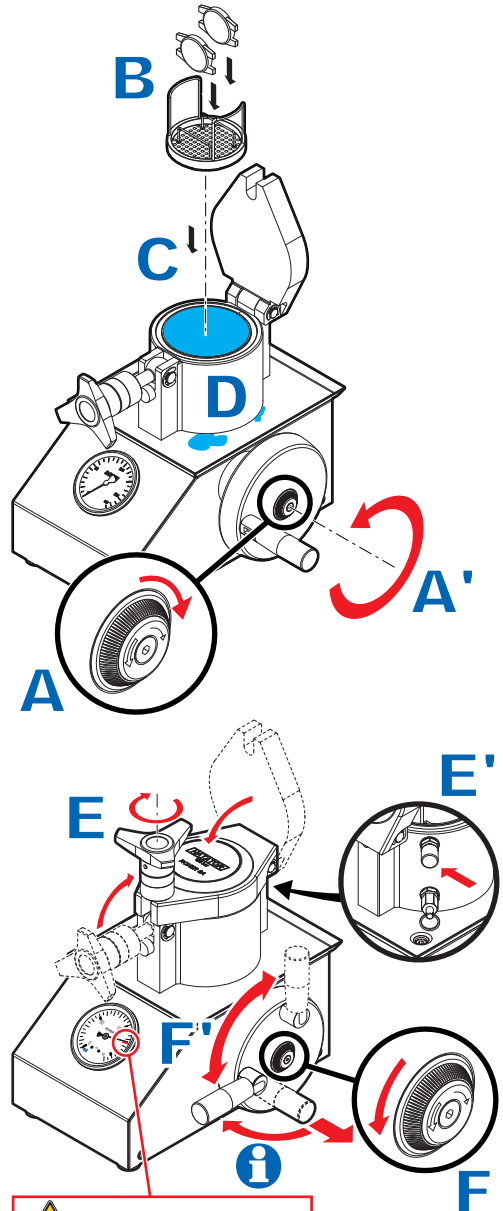

**⚠ Pmax=125 bars**

## Reducing the pressure

**i** When the test is finished

**G.** Turn the knurled ring and lower the pressure (**G'**).

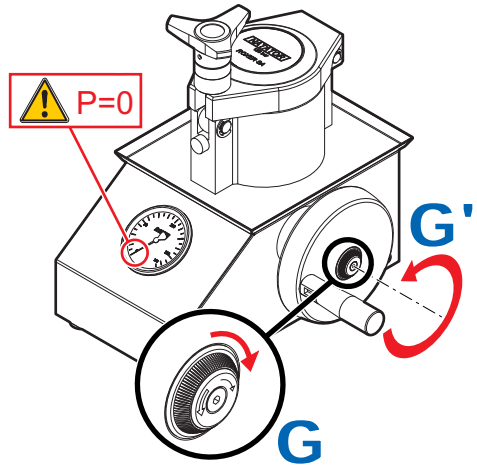

**H.** Unscrew and disengage the handle then open the tank (**H'**).

**i** If the lid resists, press the purge push-button.

**I.** Remove the basket.

**J.** Take out the watch.

