

TECHNICAL GUIDE
&
PARTS CATALOGUE

Cal.VD3 Series
(VD31B/32B)

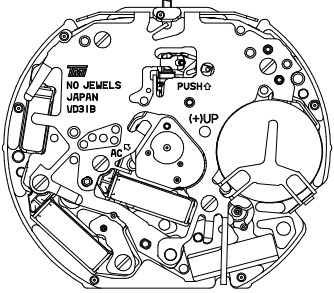
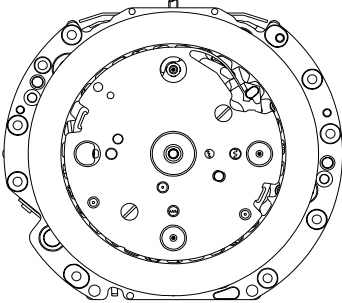
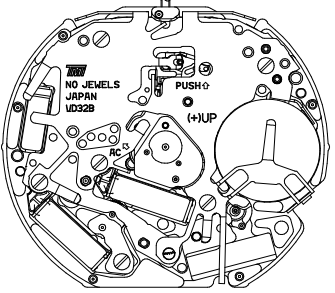
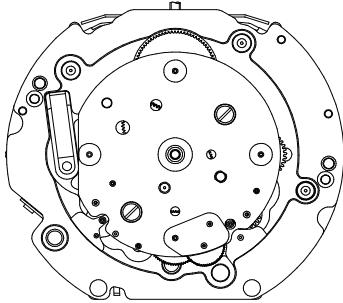

ANALOGUE QUARTZ

	Cal. No.	VD31B	VD32B
Movement		 	 
	Movement size		
	Outside diameter	φ29.50 mm × 26.00 mm (3H-9H)	
	Casing diameter	φ28.80 mm	
	Total height	4.57 mm	3.97 mm
Time indication		3 Hands (Hour, Minute, Second) Dual time of 24 hour, 24 hour hands Calendar	3 Hands (Hour, Minute, Second) Dual time of 24 hour, 24 hour hands
Driving system		Two pole stepping motor Step motor 2 pieces	
Additional mechanism		Electronic circuit reset switch Second setting device Time difference correction Date setting	Electronic circuit reset switch Second setting device Time difference correction
		[Time] Indicated by Hour, Minute, Second and 24 hour hands Dual time of 24 hour hand [Dual time of 24 hour] ± 1 hour / push	
Antimagnetic		≥ 1600 A/m	
Accuracy		Less than ± 20 seconds : Monthly rate at normal temperature range	
Battery		SR920SW (Silver oxide battery) Battery life is approximately 3 years	
Measuring gate by quartz tester		Use 10 second gate *Set the winding stem with crown at the normal position	
Jewels		0 Jewel	
Crown position	Normal position	Free	Free
	First click	Left rotation	Free
		Right rotation	Date setting
Second click		Time setting with stop-second device	-
Buttons	Button A	- 1 hour / push Time difference correction	
	Button B	+ 1 hour / push Time difference correction	

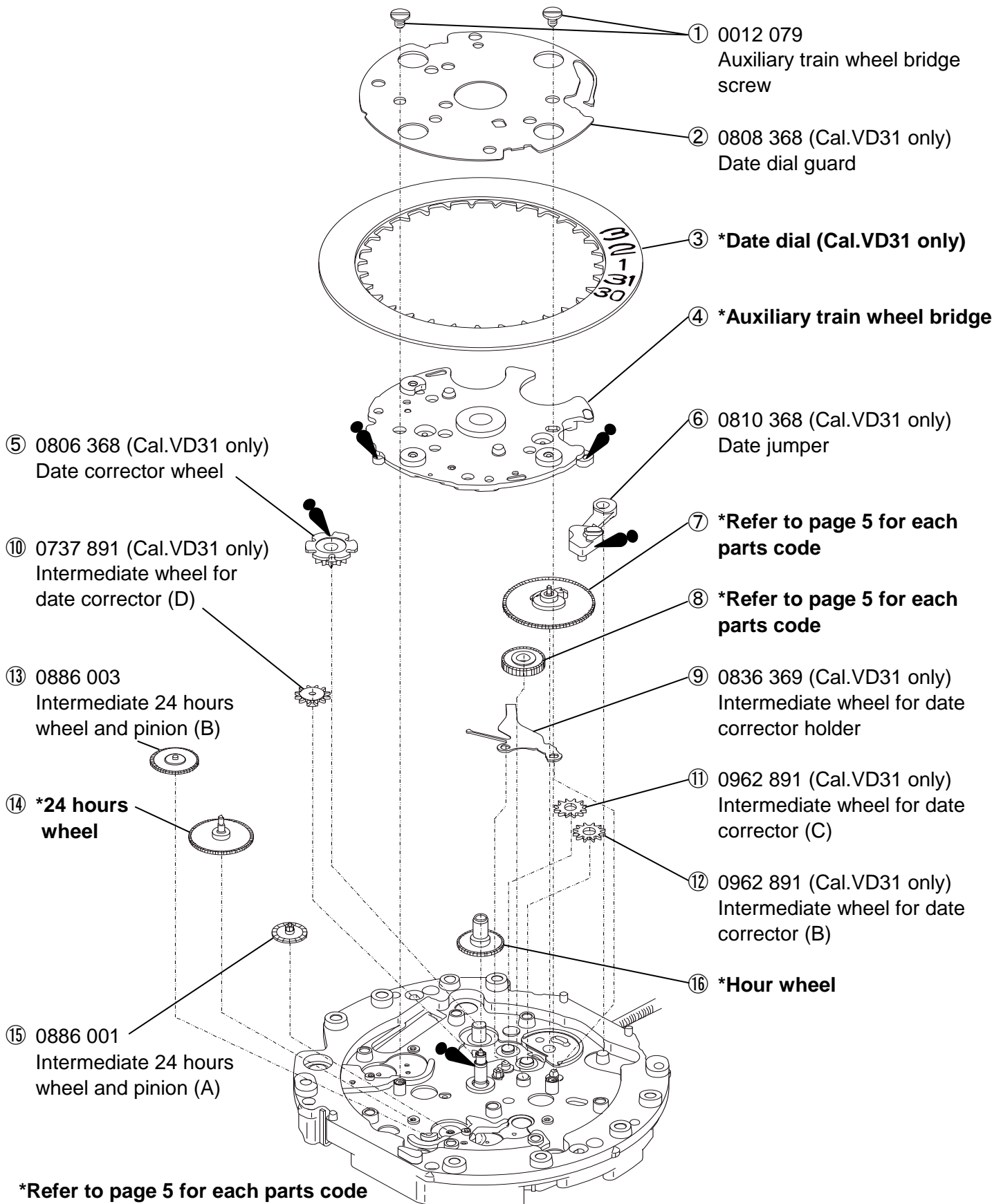
Disassembling procedures Figs. ① → ④③	Lubricating : Types of oil		A3a / Moebius 9010
Reassembling procedures Figs. ④③ → ①			A2a / Moebius 9030
	Oil quantity		Normal quantity



*Refer to page 5 for each parts code

Disassembling procedures Figs. ① → ④③	Lubricating : Types of oil		A3a / Moebius 9010
Reassembling procedures Figs. ④③ → ①			A2a / Moebius 9030
	Oil quantity		Normal quantity

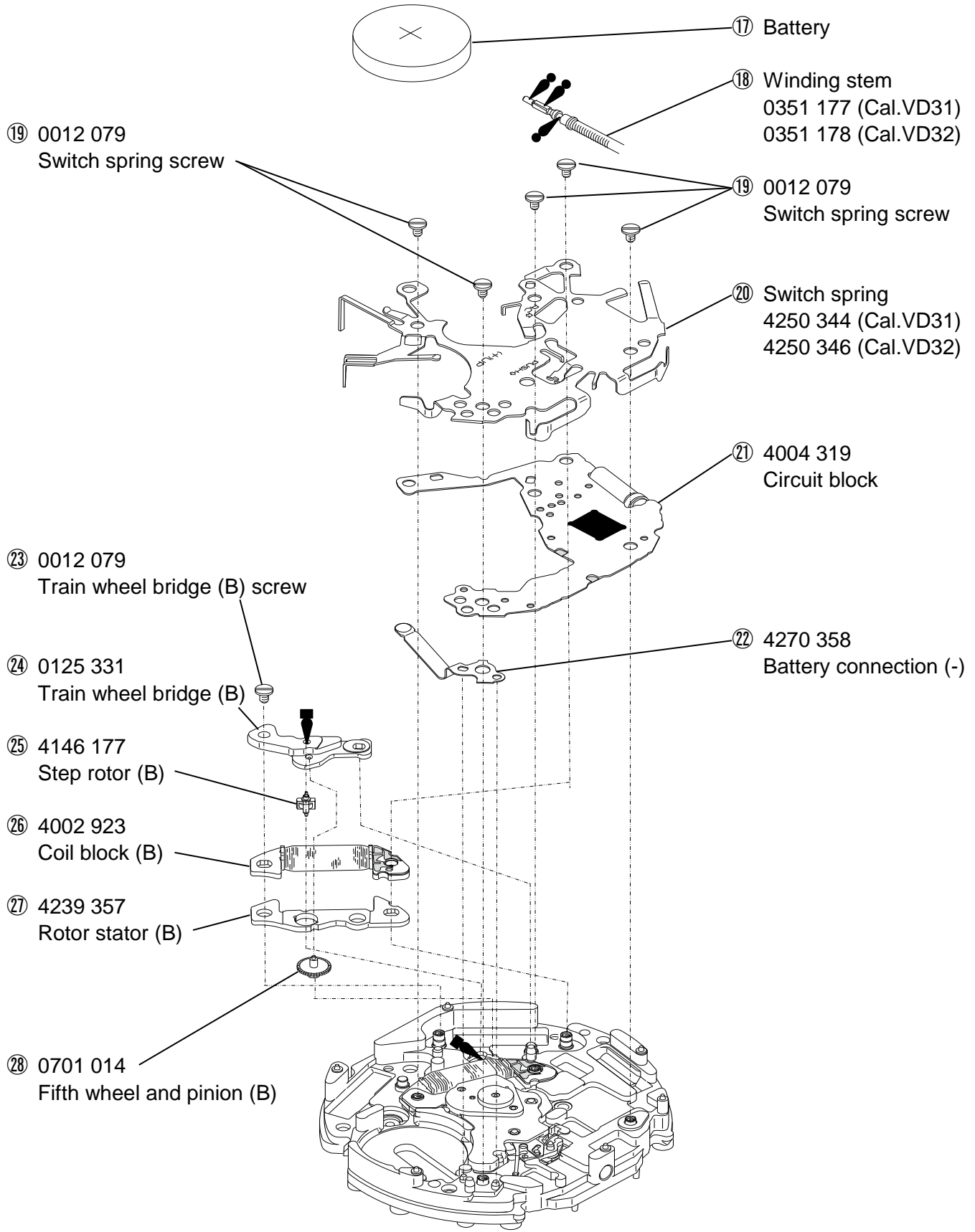

Disassembling procedures Figs. ① → ④③	Lubricating : Types of oil	
Reassembling procedures Figs. ④③ → ①		A3a / Moebius 9010
		A2a / Moebius 9030
		A3a (S-6)
	Oil quantity	Normal quantity

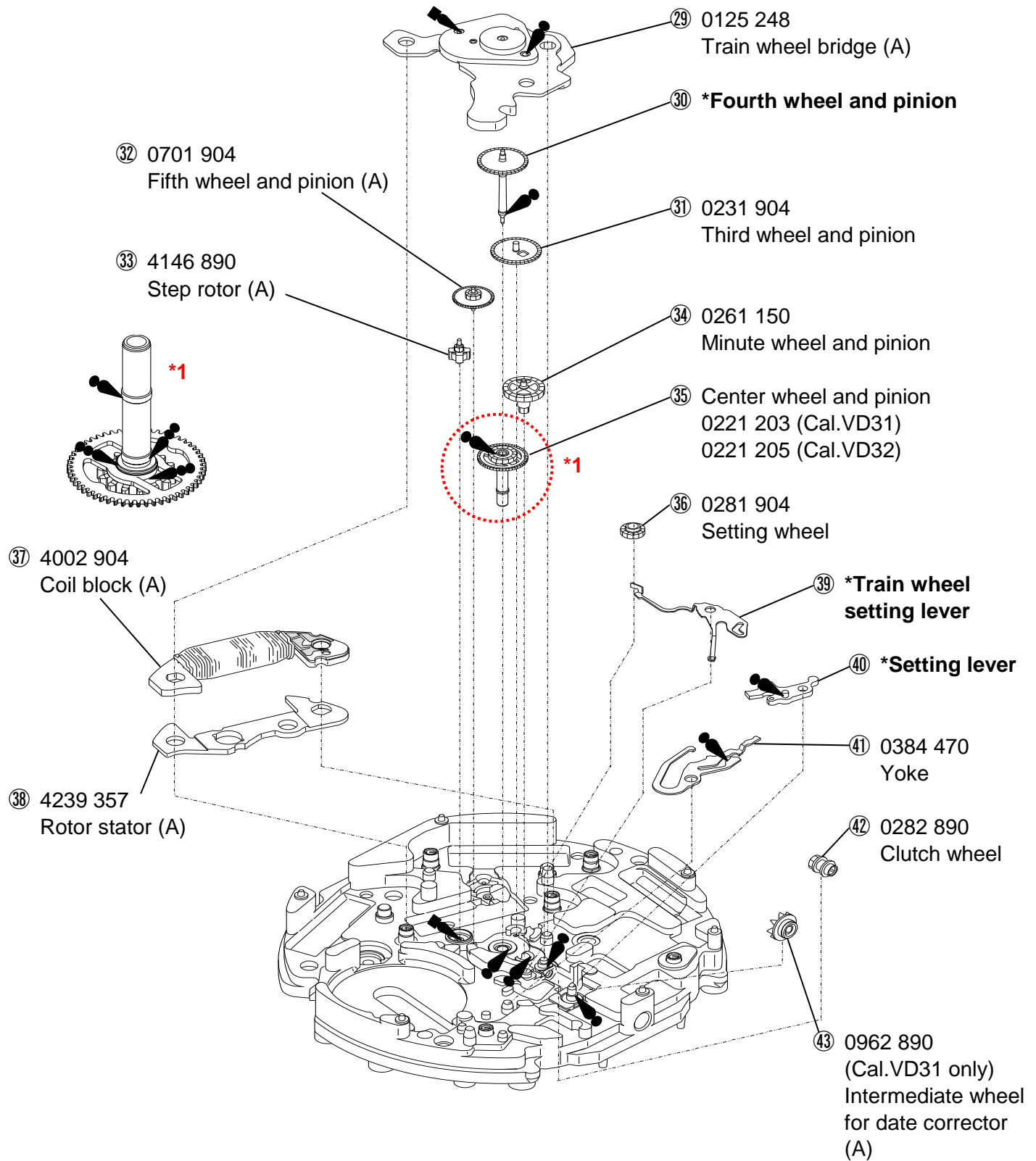





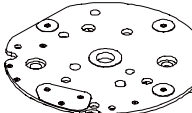
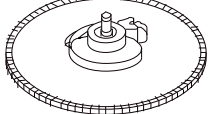
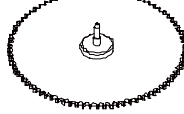

*Refer to page 5 for each parts code

Remarks:

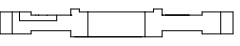
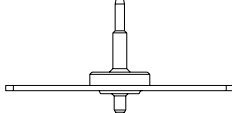
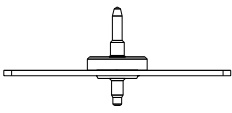
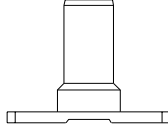
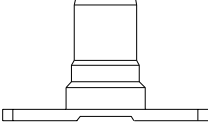
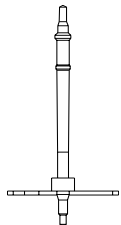
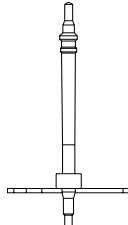
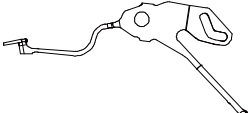
③ Date dial (Cal.VD31 only)

Part code	Position of crown	Position of date frame	Color of figure	Color of background
0878 165	3H	6H	Black	White
0878 258	3H	6H	White	Black
0148 117	9H	6H	White	Black

Page	No	Parts name	Parts code VD31	Parts form	Parts code VD32	Parts form
2	④	Auxiliary train wheel bridge	0126 368		0126 357	
	⑦	Small hour hand wheel (Cal.VD31)	0157 006		0157 130	
		24 hour hand wheel (Cal.VD32)				
	⑧	Intermediate date driving wheel (Cal.VD31)	0817 368		0817 357	
		Intermediate small hour hand wheel (Cal.VD32)				
	⑭	24 hours wheel	0902 016		0902 015	
⑯	Hour wheel	0271 407		0271 406		
4	⑳	Fourth wheel and pinion	0241 178		0241 177	
	㉑	Train wheel setting lever	0391 368		0391 357	
	㉒	Setting lever	0383 368		0383 470	

***All parts code are subject to change without notice.**

•The explanation here is only for the particular point of Cal.VD31&VD32

1.REMARKS ON INSTALLING THE BATTERY

(1) Battery

•How to install the battery

- ① Remove the hook of the switch springs battery clamp portion.
- ② Insert the battery sideways, and have the hook of the switch springs battery clamp portion catch the main plate.

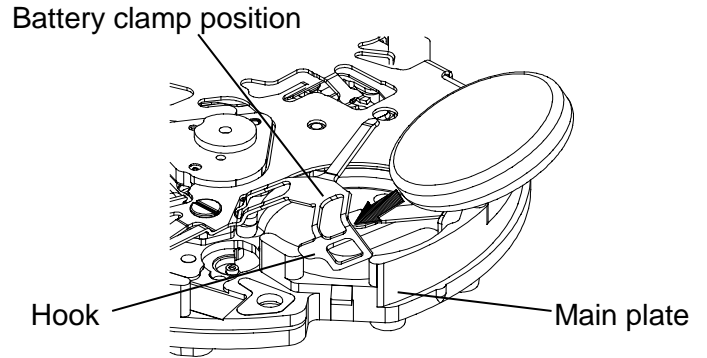
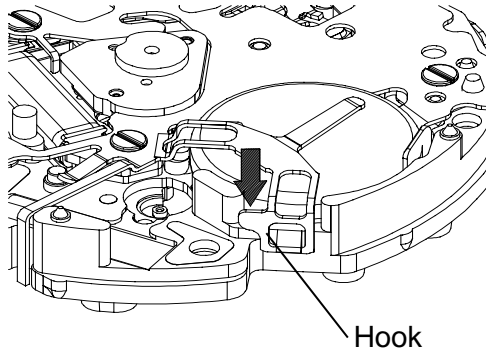

- (2) After the battery is replaced with a new one or after the battery is reinstalled following the repairing procedures, Be sure to touch the short-circuit the AC terminal of circuit block and the switch spring with conductive tweezers to reset the circuit as illustrated at right.

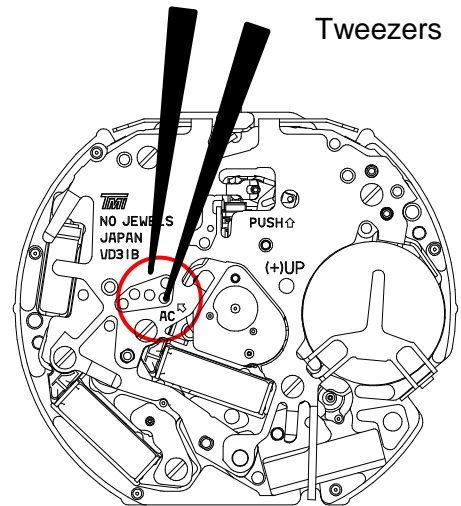
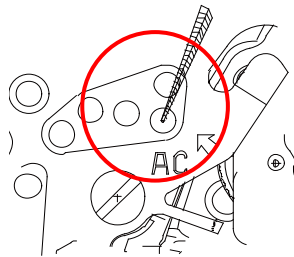

- (3) When the battery replaced with a new one, the time information stored in the built-in IC and the time indicated by the dual time of 24 hour hand do not correspond with each other. Reset the dual time of 24 hour hand to "0" position following the procedure below. If the dual time of 24 hour hand should move improperly, also follow the same procedure.

Note

Refer to page 8 for each adjustment method.

2.To remove the winding stem

- (1) set the winding stem to normal position.
- (2) While pushing the indented portion of the arrow, pull out the winding stem.

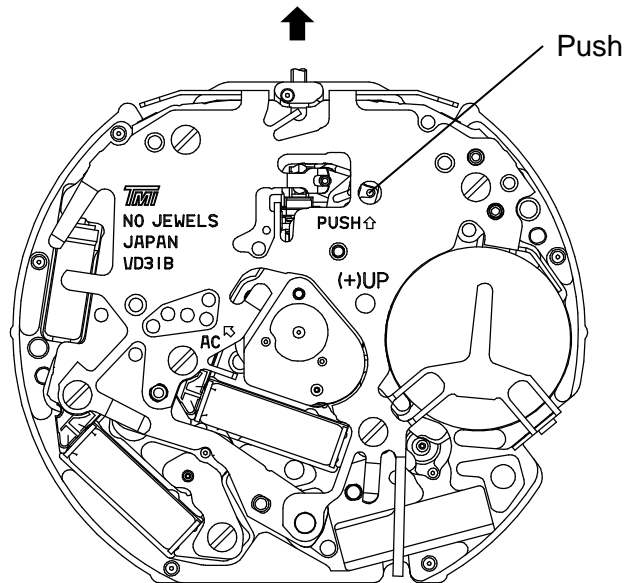

3.How to attach hands

Please put on the metal plate so as to avoid 6 protrusions.(Right figure:place of red circle)

- *Install the hour, minute and second hands at the "12" o'clock position.
- *Install the 24 hour indicator at the "24" position.
- *Install the dual time of 24 hour hand at the "24" position respectively.

[Reference] The power of press hands

Minute & Hour Hands	< 5kg
Second Hand	< 5kg
24 hour indicator	< 3kg
Dual time of 24 hour hand	< 3kg

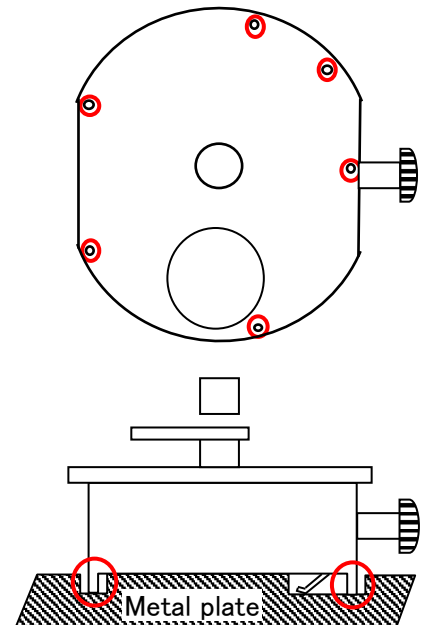

DISPLAY AND CROWN / BUTTON OPERATION

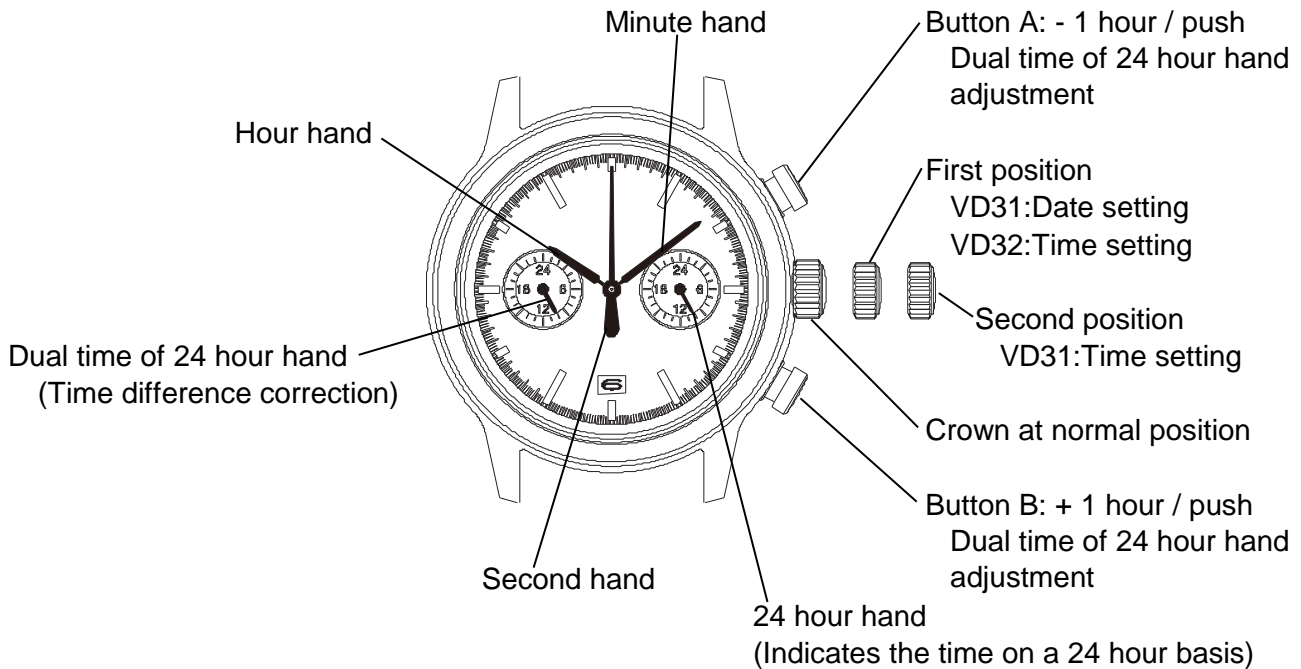

ADJUSTING THE DUAL TIME OF 24 HOUR HAND POSITION

Before setting the time, check if the dual time of 24 hour hand is in the "0" (24 o'clock) position. If the dual time of 24 hour hand is not in the "0" position, reset them following the procedure below. The battery setting and after battery change, please execute the "0" position adjustment.

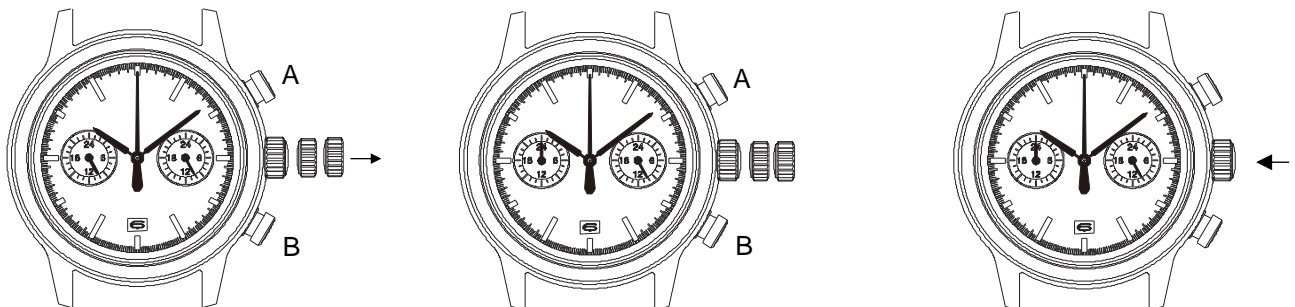

1. Pull out the crown.
VD31: second click
VD32: first click

2. Keep the buttons A & B pressed at the same time more than 2 seconds, and then release the buttons.

*Dual time of 24 hour hand moves. Returned to where it was. However, confirmation is difficult because the amount of movement is small.

3. Press button A or B to reset the dual time of 24 hour hand to "0" position.

*By pressing button A the hand move counter clockwise.

*By pressing button B the hand move clockwise.

*Press and hold the button, possible to fast-forward modification.

4. Push the crown back to the normal position.

TIME SETTING



1.Pull out the crown when the second hand is at the 12 o'clock position.

[Crown position]

VD31:second click

VD32:first click

2.Turn the crown to set the hour and minute hands.
(Check that 24 hour hand is set correctly)

3.Push the crown back normal position in accordance with a time signal.

Note

*The 24 hour hand moves correspondingly with the hour hand.

*The moment of the date changes is midnight. when setting the hour hand, make sure that AM/PM is correctly set by using the 24 hour hand as an AM/PM indicator.

■ Using the time difference correction

When moving to a country or area which is in a different timezone, the current time in the local time can be corrected.

1.Crown at the normal position.

2.To adjust the time by pressing the button A or B.

*By pressing button A the hands move counter clockwise. - 1 hour / push

*By pressing button B the hands move clockwise. + 1 hour / push

TIME SETTING (DUAL TIME OF 24 HOUR HAND)

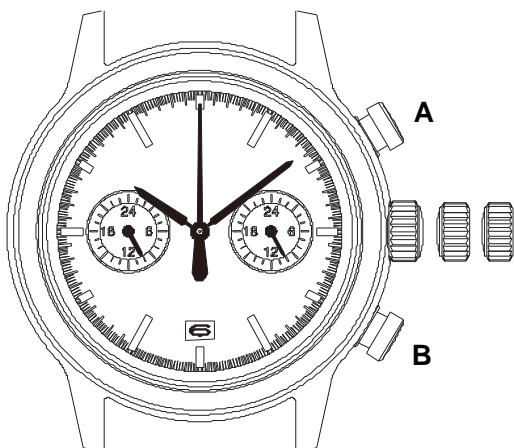

1.Pull out the crown when the second hand is at the 12 o'clock position.

[Crown position]

VD31:second click

VD32:first click

2.To adjust the time by pressing the buttons A or B.

By pressing button A the hands move counter clockwise.

By pressing button B the hands move clockwise.

*Press and hold the button, possible to fast-forward modification.

3.Push the crown back in to the normal position.

DATE SETTING (Cal.VD31 only)

*Before setting the date, be sure to set the time.

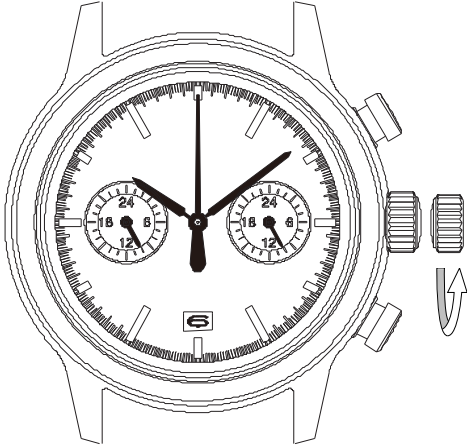

- 1.Pull out the crown to the first click.
- 2.Turn the crown to clockwise until the next date appears.
- 3.Push the crown back in to the normal position.

Note

*Do not set the date during any time between 9:00 P.M. and 1:00 A.M.
Otherwise, the date may not change properly. If it is necessary to set the date during that time period,
First change the time to any time outside it, set the date and then reset the correct time.