

ETA 955...2

COMMUNICATION
TECHNIQUE

TECHNISCHE
MITTEILUNG

TECHNICAL
COMMUNICATION

10¹/₂"^{ou}
oder
or 11¹/₂"

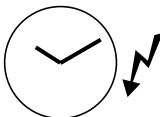
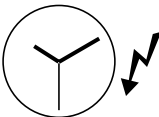
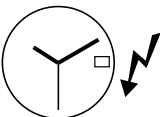
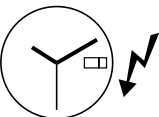
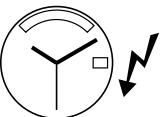
					
	LONGLIFE	E.O.L.	E.O.L.	E.O.L.	E.O.L.
Hauteur mouvement Werkhöhe Movement height	2,50 mm	2,50 mm	2,50 mm	3,00 mm	3,00 mm
Hauteur sur pile Höhe auf Batterie Height on battery	2,62 mm	2,62 mm	2,62 mm	3,12 mm	3,12 mm
10 ¹ / ₂ " Ø 23,30 mm	955.432	955.402	955.412	955.422	
11 ¹ / ₂ " Ø 25,60 mm		955.102	955.112	955.122	955.132

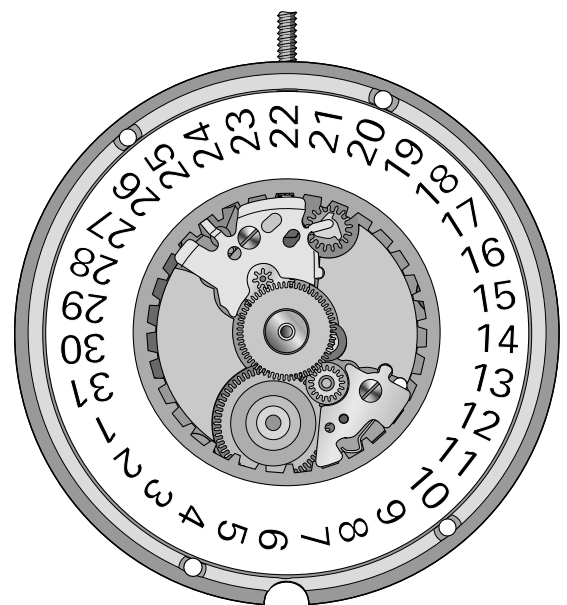
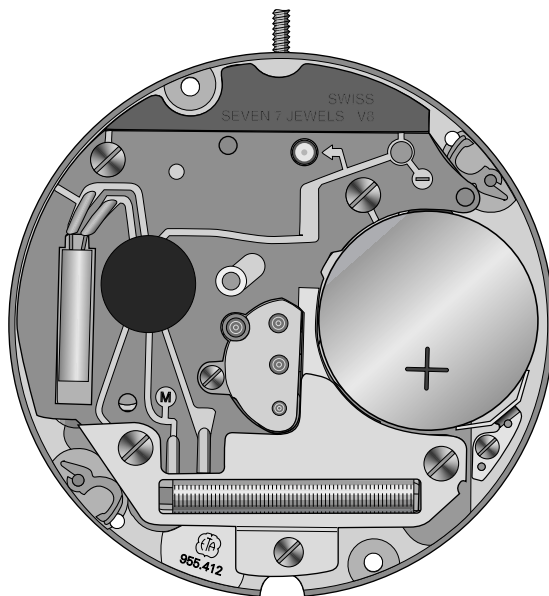

ETA SA Fabriques d'Ebauches
Marketing-Ventes
CH-2540 Grenchen

Français / Deutsch / English - 04.02.1998 / STAR / 01

Interchangeability – Auswechselbarkeit – Interchangeability

No Nr No	No Nr ISO No	LISTE DES FOURNITURES	BESTANDTEILE	LIST OF MATERIALS	Cal. – Kal. – Cal.							
					955.102	955.112	955.122	955.132	955.402	955.412	955.422	955.432
100	10.020.07	Platine, empierrée	Werkplatte, mit Steinen	Main plate, jewelled	955.102	955.112	955.122	955.132	955.402	955.412	955.422	955.432
110	10.048.07	Pont de rouage, empierré	Räderwerkbrücke, mit Steinen	Train wheel bridge, jewelled	956.112	956.112	956.112	956.112	956.112	956.112	956.112	956.112
144	10.300	Fixateur de cadran	Zifferblatthalter	Dial fastener	2850	2850	2850	2850	2850	2850	2850	2850
145	10.106	Support de cadran	Träger für Zifferblatt	Dial support	---	---	955.121	955.121	---	---	955.421	---
147	10.280	Porte-marque	Platte für Markenzeichen	Mark support	950.001	950.001	950.001	950.001	950.001	950.001	950.001	950.001
161	80.400	Tube de centre	Zentrumlagerrohr	Centre tube	956.101	956.101	956.101	956.101	956.101	956.101	956.101	956.101
203	30.012	Roue intermédiaire	Zwischenrad	Intermediate wheel	956.101	956.101	956.101	956.101	956.101	956.101	956.101	956.101
210	30.025	Roue moyenne	Kleinbodenrad	Third wheel	956.101	956.101	956.101	956.101	956.101	956.101	956.101	956.101
227	30.027	Roue de seconde	Sekundenrad	Second wheel	956.101	956.101	956.101	956.101	956.101	956.101	956.101	---
227/3	30.027.18	Roue de seconde, sans seconde au centre	Sekundenrad, ohne Zentralsekunde	Second wheel, without sweep second	---	---	---	---	---	---	---	956.031
242	31.083	Chaussée avec entraîneur	Minutenrohr mit Mitnehmer	Cannon pinion with driver	956.101	956.101	956.101	956.101	956.101	956.101	956.101	---
242/1	31.083.18	Chaussée avec entraîneur, sans seconde au centre	Minutenrohr mit Mitnehmer, ohne Zentralsekunde	Cannon pinion with driver, without sweep second	---	---	---	---	---	---	---	956.031
255	31.046	Roue des heures	Stundenrad	Hour wheel	---	---	956.121	956.121	---	---	956.121	---
255/1	31.046.06	Roue des heures, montée	Stundenrad, montiert	Hour wheel, assembled	956.101	956.101	---	---	956.101	956.101	---	956.101
260	31.041	Roue de minuterie	Wechselrad	Minute wheel	956.101	956.101	956.101	956.101	956.101	956.101	956.101	956.101
405	51.020.21	Tige de mise à l'heure, Ø filetage 0,90 mm	Stellwelle, Gewindedurchmesser 0,90 mm	Handsetting stem, thread diameter 0.90 mm	956.101	956.101	956.101	956.101	956.101	956.101	956.101	956.101
405/4	51.021	Tige de mise à l'heure, partie mouvement	Stellwelle, Werkteil	Handsetting stem, movement part	955.101	955.101	955.101	955.101	955.401	955.401	955.401	955.401
407	31.121	Pignon coulant	Kupplungstrieb	Sliding pinion	956.101	956.101	956.101	956.101	956.101	956.101	956.101	956.101
435	51.050	Bascule de pignon coulant	Kupplungstriebhebel	Yoke	956.112	956.112	956.112	956.112	956.112	956.112	956.112	956.112
443/1	51.080.06	Tirette, montée	Winkelhebel, montiert	Setting lever, assembled	956.101	956.101	956.101	956.101	956.101	956.101	956.101	956.101
445	51.090	Sautoir de tirette	Winkelhebelraste	Setting lever jumper	956.101	956.111	956.111	956.111	956.101	956.111	956.111	956.101
450	31.100	Renvoi	Zeigerstellrad	Setting wheel	956.101	956.101	956.101	956.101	956.101	956.101	956.101	956.101
462	10.062	Pont de rouage de minuterie	Wechselradbrücke	Minute train bridge	956.101	956.101	956.121	956.121	956.101	956.101	956.121	956.101
549	81.185	Clavette de tirette	Klemmscheibe für Winkelhebel	Setting lever spring-clip	956.101	956.101	956.101	956.101	956.101	956.101	956.101	956.101
560	56.071	Levier d'arrêt et interrupteur	Stoppehebel und Unterbrecher	Stop lever and switch	956.101	956.101	956.101	956.101	956.101	956.101	956.101	956.101
2543	33.011	Roue intermédiaire de quantième	Datum-Zwischenrad	Intermediate date wheel	---	956.111	956.111	956.111	---	956.111	956.111	---
2555	33.028	Roue entraîneuse du calendrier	Kalender-Mitnehmerrad	Calendar driving wheel	---	---	956.121	956.121	---	---	956.121	---
2556	33.020	Roue entraîneuse de l'indicateur de quantième	Datumanzeiger-Mitnehmerrad	Date indicator driving wheel	---	956.111	---	---	---	956.111	---	---
2557/1	91.440.22	Indicateur de quantième, ouverture de guichet à 3h	Datumanzeiger, für Fenster bei 3 Uhr	Date indicator, for opening at 3 o'clock	---	955.111	955.121	955.132	---	955.411	955.421	---
2561/1	91.441.42	Indicateur du jour, pour ouverture rectangulaire horizontale à 3 h	Tagesanzeiger, für rechteckiges horizontales Fenster bei 3 Uhr	Day indicator, for horizontal rectangular opening at 3 o'clock	---	---	955.121	---	---	---	955.421	---
2561/1	91.441.21	Indicateur du jour, pour ouverture en arc de cercle à 12 h	Tagesanzeiger, für bogenförmiges Fenster bei 12 Uhr	Day indicator, for circular arc opening at 12 o'clock	---	---	---	955.132	---	---	---	---
2566	53.200	Correcteur de quantième	Datumkorrektor	Date corrector	---	956.111	---	---	---	956.111	---	---
2567	53.201	Correcteur des jours	Tageskorrektor	Day corrector	---	---	956.121	956.121	---	---	956.121	---
2569	53.204	Correcteur double	Doppelkorrektor	Double corrector	---	---	956.121	956.121	---	---	956.121	---

Interchangeabilité – Auswechselbarkeit – Interchangeability

No Nr No	No Nr ISO No	LISTE DES FOURNITURES	BESTANDTEILE	LIST OF MATERIALS	Cal. – Kal. – Cal.								
					955.102	955.112	955.122	955.132	955.402	955.412	955.422	955.432	
	2570	53.026	Commande du correcteur double	Schalthebel für Doppelkorrektor	Double corrector operating lever	956.101	956.101	956.101	956.101	956.101	956.101	956.101	956.101
	2573	63.032	Ressort du sautoir des jours	Feder für Tagesraste	Day jumper spring	---	---	956.121	956.121	---	---	956.121	---
	2576	53.080	Sautoir de quantième	Datumraste	Date jumper	---	955.112	955.112	955.112	---	955.112	955.112	---
	2577	53.081	Sautoir des jours	Tagesraste	Day jumper	---	---	956.121	956.121	---	---	956.121	---
	2595	13.111	Plaque de maintien du sautoir de quantième	Halteplatte für Datumraste	Date jumper maintaining plate	---	956.101	956.101	956.101	---	956.101	956.101	---
	2780	83.171	Clavette de l'indicateur du jour	Klemmscheibe für Tagesanzeiger	Day indicator spring-clip	---	---	2648	2648	---	---	2648	---
	4000	10.513	Module électronique	Elektronik-Baugruppe	Electronic module	955.112	955.112	955.112	955.112	955.112	955.112	955.112	955.432
	4021	20.582	Stator	Stator	Stator	955.101	955.101	955.101	955.101	955.101	955.101	955.101	955.101
	4022	80.102	Entretoise du module électronique	Zwischenstück für Elektronik-Baugruppe	Electronic module distance piece	955.101	955.101	955.101	955.101	955.101	955.101	955.101	955.101
	4038	20.584	Ecran magnétique supérieur	Oberer Magnetschirm	Upper magnetic screen	955.112	955.112	955.112	955.112	955.112	955.112	955.112	955.112
	4046	20.651	Isolateur de pile	Isolation für Batterie	Battery insulator	955.101	955.101	955.101	955.101	955.101	955.101	955.101	955.101
	4211	20.580	Roto	Rotor	Rotor	956.101	956.101	956.101	956.101	956.101	956.101	956.101	956.101
	4233	80.246	Rivet de stator	Niete für Stator	Rivet for stator	956.101	956.101	956.101	956.101	956.101	956.101	956.101	956.101
	4407	20.764	Bride de masse	Massen-Bügel	Earth connector	955.101	955.101	955.101	955.101	955.101	955.101	955.101	955.101
	4412	10.601	Ressort de limitation de pile	Begrenzungsfeder für Batterie	Battery limiting spring	955.101	955.101	955.101	955.101	955.101	955.101	955.101	955.101
	4929	20.570	Pile, H. 2,10 mm	Batterie, H. 2,10 mm	Battery, H. 2.10 mm	955.101	955.101	955.101	955.101	955.101	955.101	955.101	955.101
	4929/1	4929/1	Pile spéciale, H. 2,70 m	Batterie, Spezial-Ausführung, H. 2,70 mm	Battery, special, H. 2.70 mm	955.101	955.101	955.101	955.101	955.101	955.101	955.101	955.101
	5101	10.020.01	Vis de fixation	Schraube für Werkbefestigung	Screw for case	956.401	956.401	956.401	956.401	956.401	956.401	956.401	956.401
	5102	10.020.02	Vis de fixation, spéciale	Schraube für Werkbefestigung, Spezial-Ausführung	Screw for case, special	956.401	956.401	956.401	956.401	956.401	956.401	956.401	956.401
	5110	10.048.01	Vis de pont de rouage	Schraube für Räderwerkbrücke	Screw for train wheel bridge	956.101	956.101	956.101	956.101	956.101	956.101	956.101	956.101
1)	5462	10.062.01	Vis de pont de rouage de minuterie	Schraube für Wechselradbrücke	Screw for minute train bridge	956.101	956.101	956.101	956.101	956.101	956.101	956.101	956.101
	52567	53.201.01	Vis de correcteur des jours	Schraube für Tageskorrektor	Screw for day corrector	---	---	956.121	956.121	---	---	956.121	---
1)	52573	63.032.01	Vis de ressort du sautoir des jours	Schraube für Tagesrastefeder	Screw for day jumper spring	---	---	956.121	956.121	---	---	956.121	---
1)	52595	13.111.01	Vis de plaque de maintien du sautoir de quantième	Schraube für Halteplatte für Datumraste	Screw for date jumper maintaining plate	---	956.101	956.101	956.101	---	956.101	956.101	---
	54000	10.513.01	Vis de module électronique, longue	Schraube für Elektronik-Baugruppe, lang	Screw for electronic module, long	955.112	955.112	955.112	955.112	955.112	955.112	955.112	955.112
	54000'	10.513.02	Vis de module électronique, courte	Schraube für Elektronik-Baugruppe, kurz	Screw for electronic module, short	955.112	955.112	955.112	955.112	955.112	955.112	955.112	955.112
2)	54038	20.584.01	Vis d'écran magnétique supérieur	Schraube für oberen Magnetschirm	Screw for upper magnetic screen	955.112	955.112	955.112	955.112	955.112	955.112	955.112	955.112
2)	54407	20.764.01	Vis de bride de masse	Schraube für Massen-Bügel	Screw for earth connector	955.112	955.112	955.112	955.112	955.112	955.112	955.112	955.112
			1)2) Vis identiques / Identische Schrauben / Identical screws										

955.102 / 112 / 122 / 132 / 402 / 412 / 422 / 432

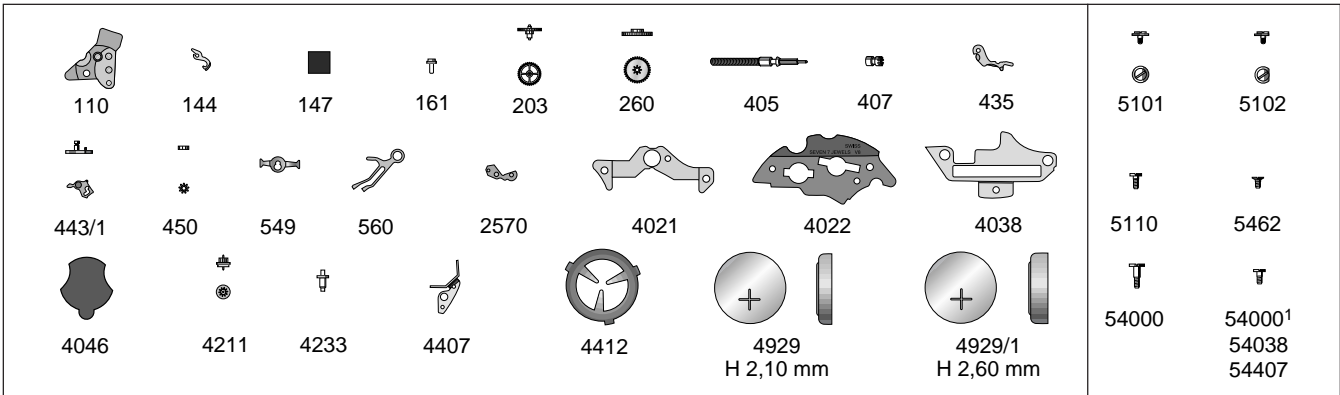

955.102 / 112 / 122 / 132 / 402 / 412 / 422

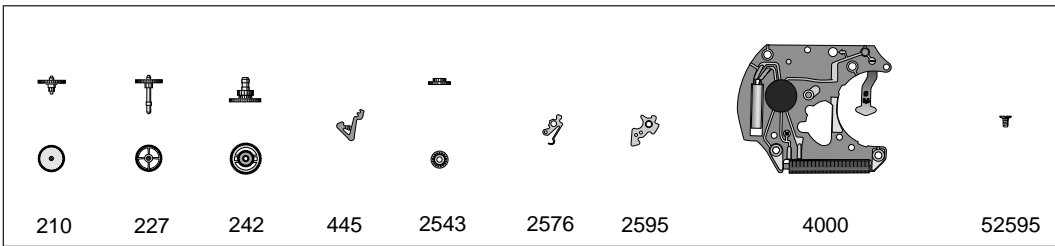

955.122 955.132

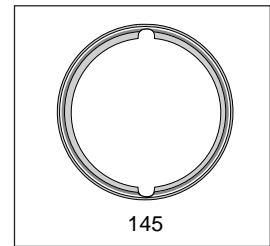

955.122 / 132 / 422

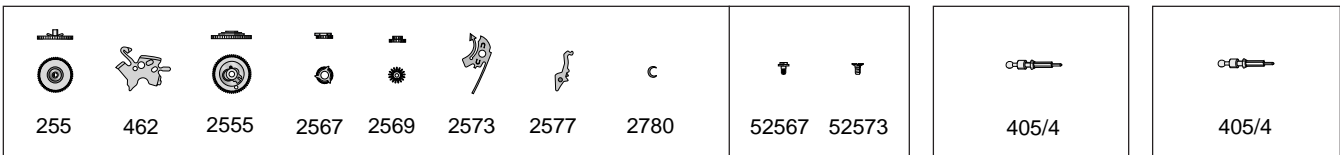

955.102 / 112

955.402 / 412 / 432

955.112 / 412

955.102 / 112

955.112

955.402 / 412

955.412

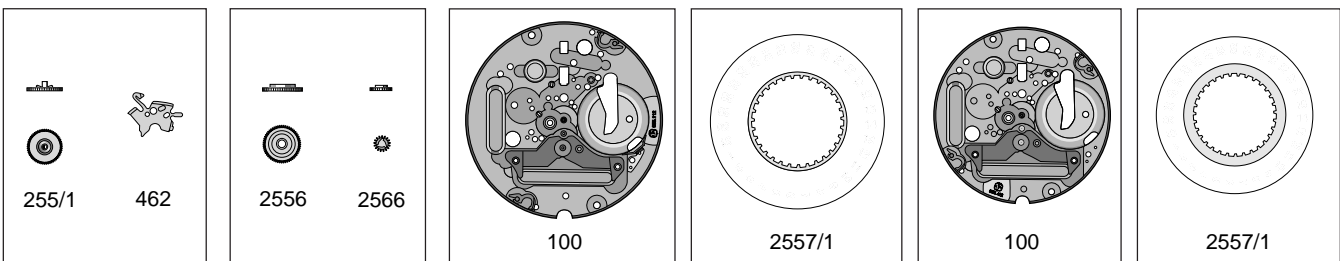

955.122

955.132

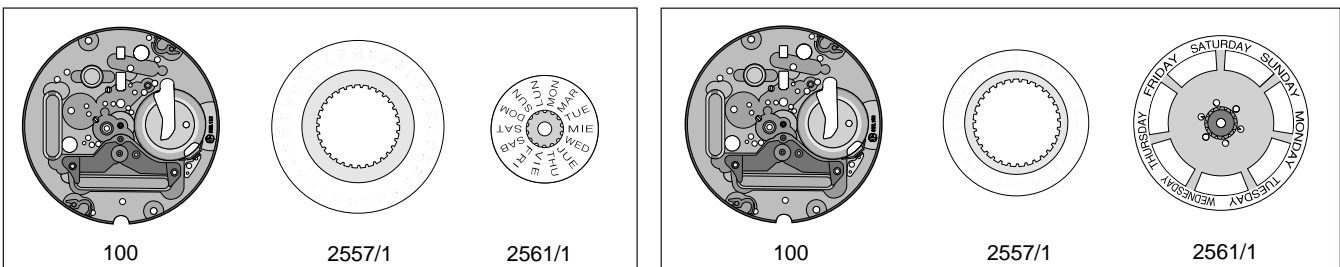

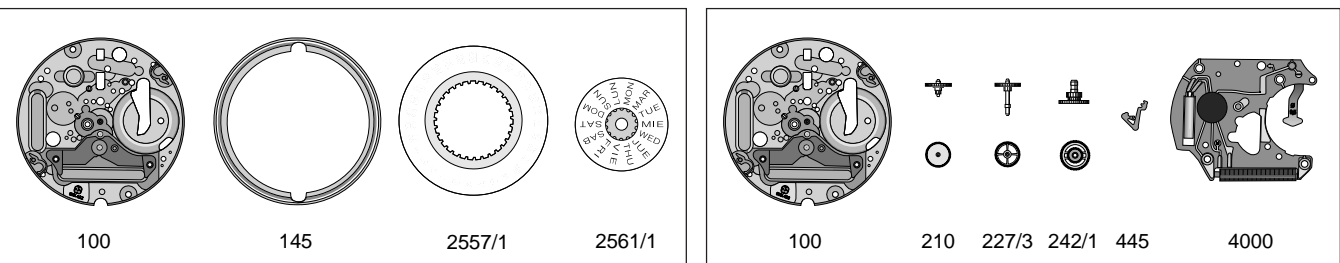

955.422

955.432



Lubrification – Schmierung – Lubrication

	Huile fine Dünnflüssiges Öl Fine oil	Moebius 9014 Moebius 9034
	Très faible lubrification Sehr kleine Menge Very little lubrication	Moebius 9014
	Huile épaisse à viscosité élevée ou graisse Dickflüssiges druckfestes Öl oder Fett Thick, pressure-resistant oil or grease	Moebius D5

Montage du mouvement de base (Liste des fournitures par ordre d'assemblage)

Zusammenstellen des Basiswerkes (Bestandteilliste in Montagereihenfolge)

Assembling of the basic movement (Parts listed in order of assembly)

100	210
161	4211
407	227
405	203
2570	560
445	110
443/1	5110 (1x)
549	

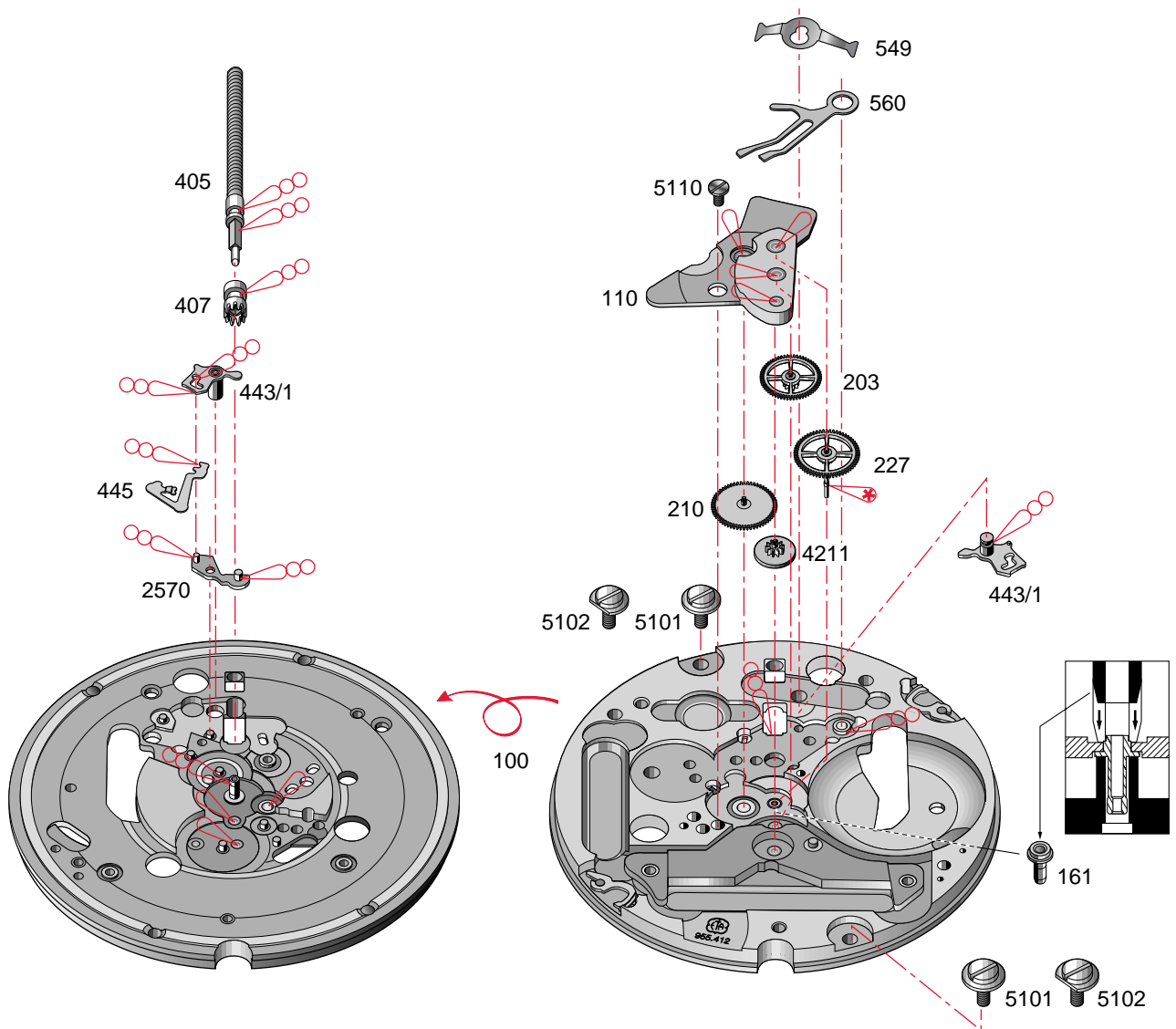

**Montage du mécanisme de mise à l'heure
et du mécanisme de calendrier**

(Liste des fournitures par ordre d'assemblage)

**Zusammenstellen des Zeigerwerkmechanismus
und des Kalendermechanismus**

(Bestandteilliste in Montagereihenfolge)

**Assembling of the handsetting
and the calendar mechanism**

(Parts listed in order of assembly)

242	2557/1
260	2556
450	2543
2566	2576
435	2595
462	52595 (1x)
5462	255/1

Lubrification – Schmierung – Lubrication

Huile épaisse à viscosité élevée ou graisse

 Dickflüssiges druckfestes Öl oder Fett
Moebius D5
Thick, pressure-resistant oil or grease

 Très faible lubrification
Moebius D5
Sehr kleine Menge
Very little lubrication

 Graisse
Moebius 9501
Fett
Jismaa 124
Grease

955.112 : 11 1/2'''

955.412 : 10 1/2'''

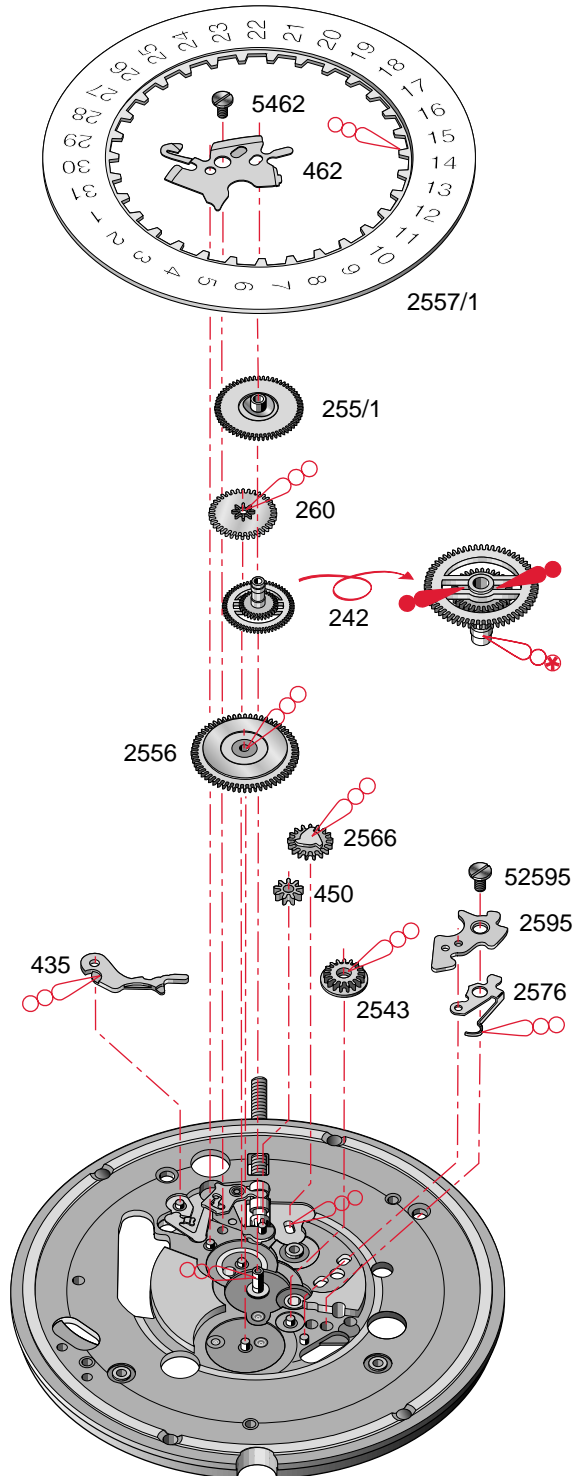

**Montage du mécanisme de mise à l'heure
et du mécanisme de calendrier**

(Liste des fournitures par ordre d'assemblage)

**Zusammenstellen des Zeigerwerkmechanismus
und des Kalendermechanismus**

(Bestandteilliste in Montager Reihenfolge)

**Assembling of the handsetting
and the calendar mechanism**

(Parts listed in order of assembly)

242	2576
260	2595
450	52595
2569	255
435	2573
462	52573 (1x)
5462	2577
2557/1	2561/1
2555	2780
2543	

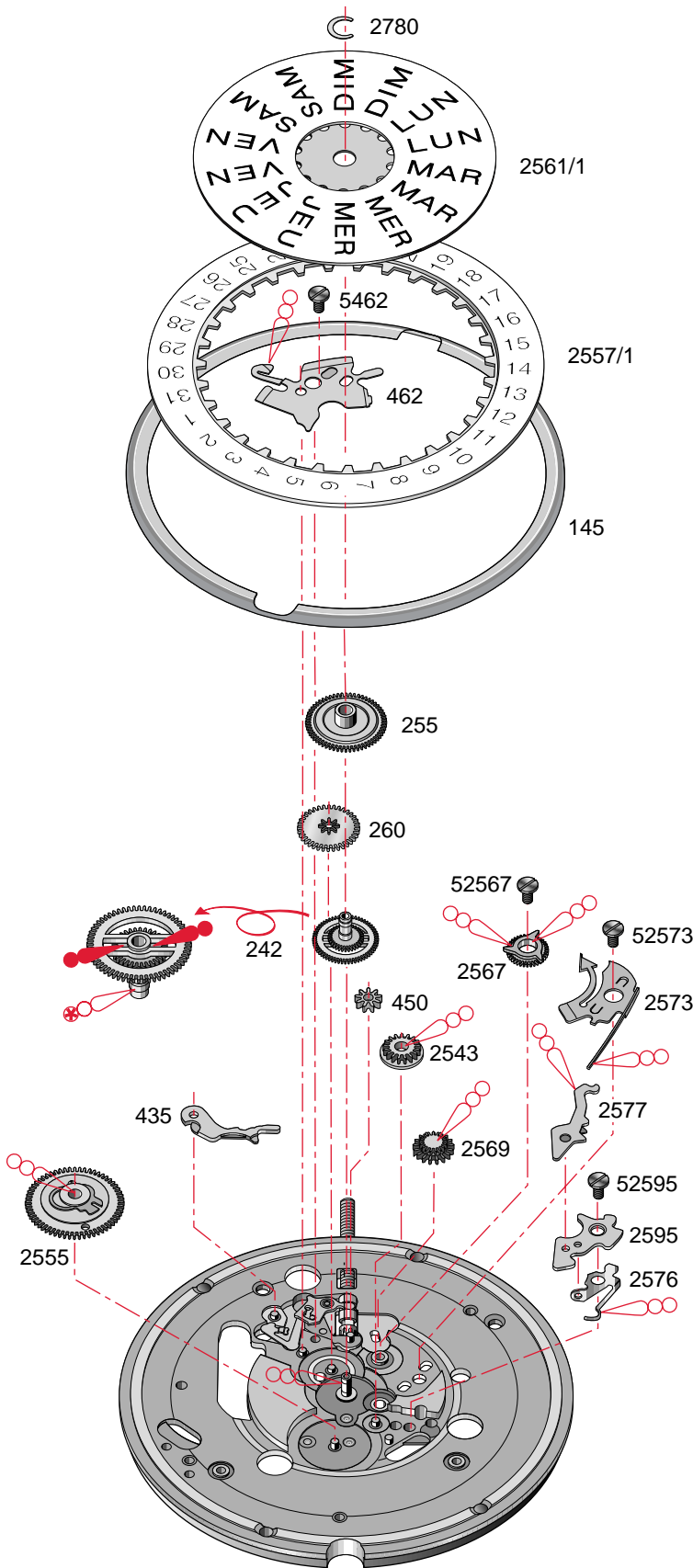

955.122 : 11¹/₂'''

955.422 : 10¹/₂'''

Lubrification – Schmierung – Lubrication

Huile épaisse à viscosité élevée ou graisse

Dickflüssiges druckfestes Öl oder Fett **Moebius D5**

Thick, pressure-resistant oil or grease

Très faible lubrification
Sehr kleine Menge
Very little lubrication

Moebius D5

Graisse
Fett
Grease

**Moebius 9501
Jismaa 124**

**Montage du mouvement de base
et de la partie électronique**

(Liste des fournitures par ordre d'assemblage)

**Zusammenstellen des Basiswerkes
und des elektronischen Teils**

(Bestandteilliste in Montager Reihenfolge)

**Assembling of the basic movement
and the electronic part**

(Parts listed in order of assembly)

4407	54000 (3x)
54407 (1x)	54000 ¹ (1x)
4022	4038
4046	54038 (1x)
4000	4929

4412



Nécessaire, si la sûreté entre le mouvement et le fond de la boîte est trop élevée.

Nur nötig, wenn Abstand Werk-Gehäuseboden zu gross.

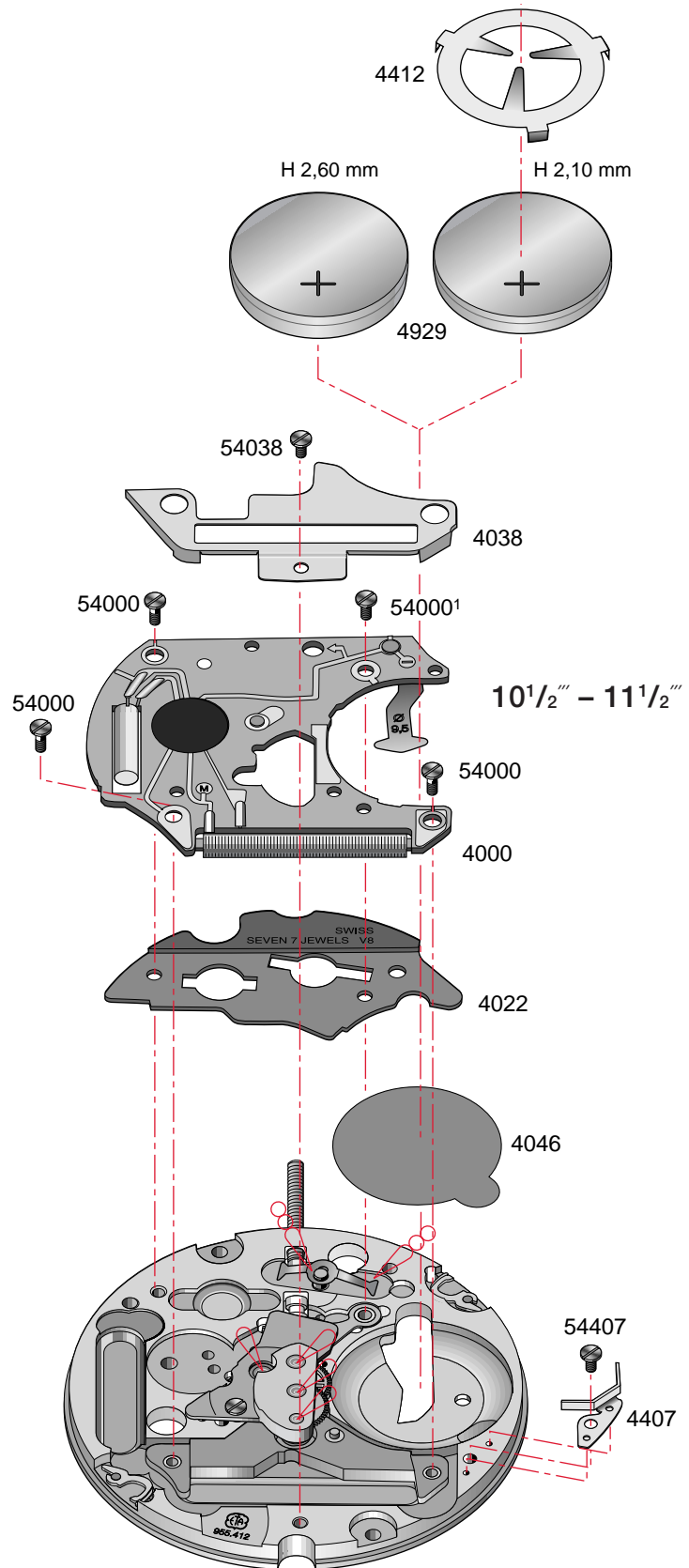
To be fitted when the clearance between the movement and the case back is too great.



Lubrification – Schmierung – Lubrication

	Huile fine Dünnflüssiges Öl Fine oil	Moebius 9014
	Huile épaisse à viscosité élevée ou graisse Dickflüssiges druckfestes Öl oder Fett Thick, pressure-resistant oil or grease	Moebius D5

Aiguillage – Zeigerwerkhöhe – Hand fitting height
955.102 / 955.112 / 955.402 / 955.412

Cal. Kal. Cal.	Aiguillage	Longueur / Länge / Length (mm)				Dépassement Höhe über Zifferblattauflage Height over dial seat			H
	Zeigerwerk- höhe	A	B	C	D	E	F	G	
	Hand fitting height	Chaussée Minutenrohr Cannon pinion	Roue des heures Stundenrad Hour wheel	Pignon des secondes Sekunden- trieb Second wheel pinion	Tube de centre Zentrumrohr Centre tube	Chaussée Minutenrohr Cannon pinion	Roue des heures Stundenrad Hour wheel	Pignon des secondes Sekunden- trieb Second wheel pinion	
955.102 955.112 955.402 955.412	réduit - niedrig reduced*	1,66	0,89	3,63	1,70	0,90	0,65	1,25	0,60
	1 normal	1,88	1,06	3,88	1,70	1,10	0,80	1,50	0,85
	3**	2,38	1,56	4,38	1,70	1,60	1,30	2,00	1,35
	4**	2,63	1,81	4,63	1,70	1,85	1,55	2,25	1,60
	5**	2,88	2,06	4,88	1,70	2,10	1,80	2,50	1,85

* Pour aiguillage 0 (réduit), cadran épaisseur 0,30
Für Zeigerwerkhöhe 0 (niedrig), Zifferblattstärke 0,30
For hand fitting height 0 (reduced), dial thickness 0.30

** Livraison contre supplément de prix, délai sur demande
Lieferung gegen Aufpreis, Lieferfrist auf Anfrage
Delivery with surcharge, delivery schedule on demand

Aiguillage – Zeigerwerkhöhe – Hand fitting height
955.122 / 955.132 / 955.422

Cal. Kal. Cal.	Aiguillage Zeigerwerk- höhe Hand fitting height	Longueur / Länge / Length (mm)				Dépassement Höhe über Zifferblattauf- lage Height over dial seat			H
		A	B	C	D	E	F	G	
		Chaussée Minutenrohr Cannon pinion	Roue des heures Stundenrad Hour wheel	Pignon des secondes Sekunden- trieb Second wheel pinion	Tube de centre Zentrumrohr Centre tube	Chaussée Minutenrohr Cannon pinion	Roue des heures Stundenrad Hour wheel	Pignon des secondes Sekunden- trieb Second wheel pinion	
955.122 955.132 955.422	3 normal	2,38	1,56	4,38	1,70	1,10	0,80	1,50	1,35

STAR / 01

Aiguillage – Zeigerwerkhöhe – Hand fitting height
955.432

Cal. Kal. Cal.	Aiguillage Zeigerwerk- höhe Hand fitting height	Longueur / Länge / Length (mm)				Dépassement Höhe über Zifferblattauf- lage Height over dial seat	
		A	B	C	D	E	F
		Chaussée Minutenrohr Cannon pinion	Roue des heures Stundenrad Hour wheel	Pignon des secondes Sekundentrieb Second wheel pinion	Tube de centre Zentrumrohr Centre tube	Chaussée Minutenrohr Cannon pinion	Roue des heures Stundenrad Hour wheel
955.432	réduit – niedrig* reduced	1,66	0,89	3,03	1,70	0,90	0,65
	1 normal	1,88	1,06	3,03	1,70	1,10	0,80
	3**	2,38	1,56	3,03	1,70	1,60	1,30
	4**	2,63	1,81	3,03	1,70	1,85	1,55
	6**	3,13	2,31	3,03	1,70	2,35	2,05

STAR / 01

* Pour aiguillage 0 (réduit), cadran épaisseur 0,30
Für Zeigerwerkhöhe 0 (niedrig), Zifferblattdicke 0,30
For hand fitting height 0 (reduced), dial thickness 0.30

** Livraison contre supplément de prix, délai sur demande
Lieferung gegen Aufpreis, Lieferfrist auf Anfrage
Delivery with surcharge, delivery schedule on demand

Contrôles électriques – Elektrische Kontrollen – Electrical tests

955.402
955.412
955.422
955.432

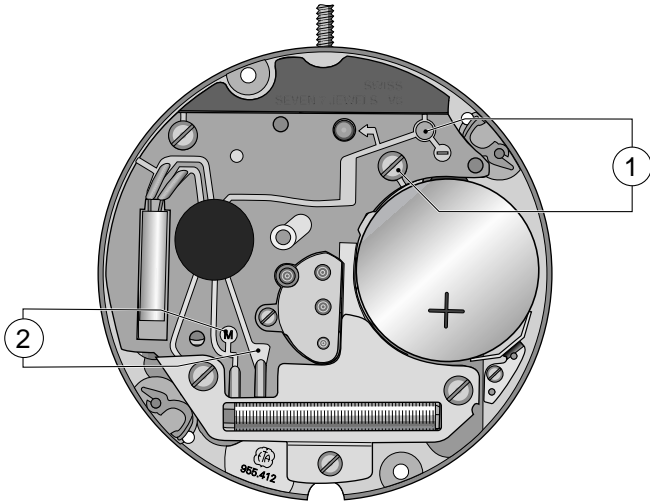

955.102
955.112
955.122
955.132

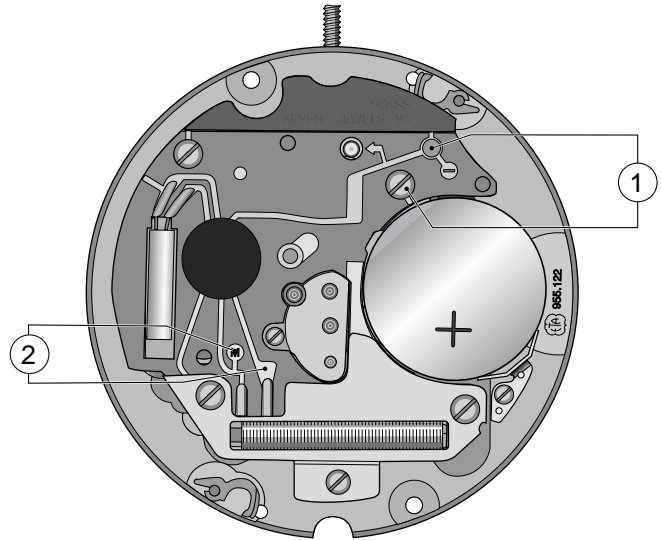

955.402
955.412
955.422

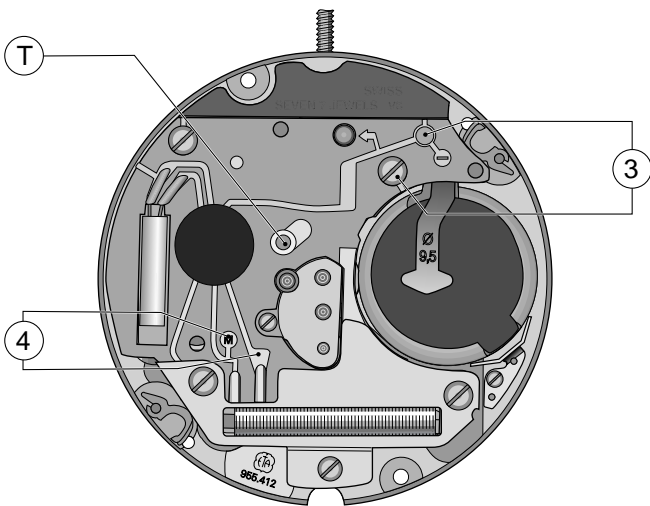

955.432

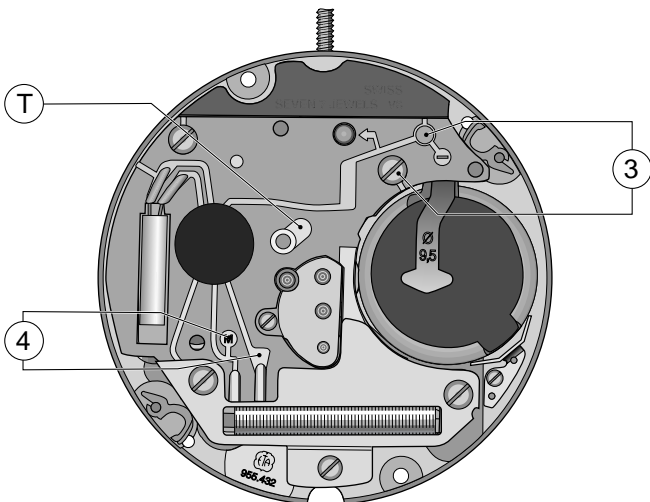
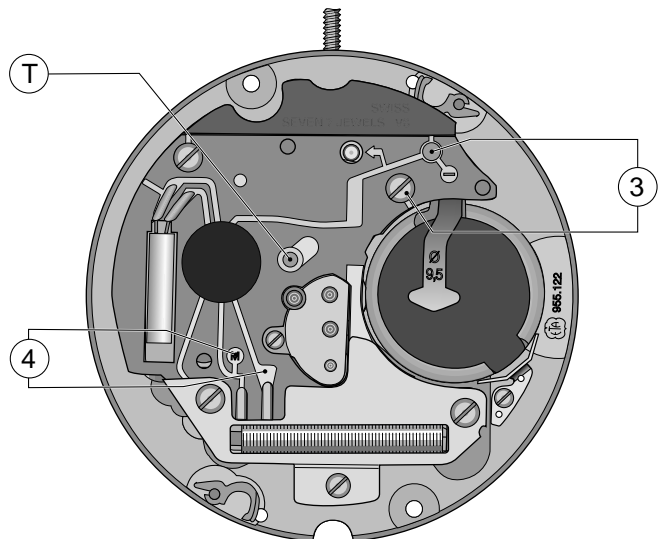

Contrôles électriques – Elektrische Kontrollen – Electrical tests

Position Messpunkt Position	Echelle de mesure Einstellung Messgerät Setting of apparatus	Mesure Messung Measurement	Contrôle Kontrolle Test	Remarques Bemerkungen Remarks	
1	2 V (Ri ≥ 10 kΩ / V)	1,55 V	Tension de la pile Spannung der Batterie Battery voltage	Mesure avec pile. Messung mit Batterie. Measurement with battery.	
2	1 V (Ri ≥ 10 kΩ / V)	L'aiguille du multimètre oscille en sens + et –. Zeiger im Messgerät pulsiert im + und – Sinn. Hand of the measuring apparatus oscillates in + and – direction.	Impulsions à la sortie du circuit intégré: Ausgangsimpulse am integrierten Schaltkreis: Impulses at output of integrated circuit: 955.432 955.102/112/122/132 955.402/412/422 12 / min. 1 / s	Mesure avec une pile contrôlée. Messung mit kontrollierter Batterie. Measurement with controlled battery.	
3	2 V	<p style="text-align: center;">≤ 1,30 V</p> <p>955.432 955.102/112/122/132 955.402/412/422</p> <p>Mettre en contact le point ⊕ et la piste ⊖. Commande du moteur avec 16 pas/s. ⊕ Punkt mit der ⊖ Spur verbinden. Motorantrieb mit 16 Schritten/S.</p> <p>Connect ⊕ point with the ⊖ conductor. Motor driven with 16 steps/s.</p>	<p>Mettre en contact le point ⊕ et la piste ⊖. Commande du moteur avec 8 pas/s à 1,55 V et 32 pas/s avec tension ≤ 1,30 V (E.O.L.). ⊕ Punkt mit der ⊖ Spur verbinden. Motorantrieb mit 8 Schritten/S bei 1,55 V und 32 Schritten/S mit Spannung ≤ 1,30 V (E.O.L.). Connect ⊕ point with the ⊖ conductor. Motor driven with 8 steps/s at 1.55 V and 32 steps/s with voltage ≤ 1.30 V (E.O.L.).</p>	<p>Limite inférieure de la tension de fonctionnement</p> <p>Untere Funktionsspannungsgrenze</p> <p>Lower working-voltage limit</p>	<p>Mesure sans pile, alimentation extérieure variable, en descendant de 1,55 V à l'arrêt du mouvement.</p> <p>Messung ohne Batterie mit variabler Speisung von aussen, Spannung von 1,55 V reduzieren bis zum Stillstand des Werkes.</p> <p>Measurement without battery, with variable external power supply, starting with 1.55 V, lower tension until movement stops.</p>
	10 μA	<p>955.432 955.102/112/122/132 955.402/412/422</p> <p>≤ 0,70 μA ≤ 1,30 μA</p> <p>Saut de 4 pas toutes les 4 sec. lorsque la tension d'alimentation < 1,30 V. 4-Schritte-Sprung alle 4 Sek. wenn Speisepannung < 1,30 V. 4 steps jump every 4 sec., when feed voltage < 1.30 V.</p>	<p>E.O.L. Consommation supérieure à la valeur normale. E.O.L. Stromaufnahme über Normalwert. E.O.L. Consumption higher than in normal operation.</p>	<p>Mesure sans pile, avec tension d'alimentation < 1,30 V, Fonction E.O.L après ~ 2 min. Messung ohne Batterie, mit Speisepannung < 1,30 V, E.O.L-Funktion nach ca. 2 Min. Measurement without battery, with feed voltage < 1.30 V, E.O.L function after about 2 min.</p>	
	≤ 0,5 μA	<p>Fonctionnement de l'interrupteur en pos. 3 de la tige de mise à l'heure. Funktion des Stopphebels, Pos. 3 der Zeigerstellwelle. Function of stop lever, pos. 3 of handsetting stem.</p>	<p>Mesure sans pile, avec alimentation extérieure 1,55 V. Messung ohne Batterie, mit Speisegerät 1,55 V. Measurement without battery, with external power supply 1.55 V.</p>		
4	● 10 kΩ 200 μA	1,3 – 1,8 kΩ 110 – 155 μA	Continuité du bobinage Zustand der Spule Condition of coil		
<p>Ohmmètres avec tension de mesure supérieure à 0,40 V inappropriés, tension recommandée 0,20 V. ● Ohmmeter mit Prüfspannung über 0,40 V ungeeignet, empfohlene Spannung 0,20 V. Ohmmeter with a test voltage higher than 0.40 V unsuitable, recommended voltage 0.20 V.</p>				<p>Température ambiante 20°C. Raumtemperatur 20°C. Ambient temperature 20°C.</p>	



ETA SA Fabriques d'Ebauches
Marketing-Ventes
CH-2540 Grenchen

Tél. 032 655 71 11
Téléfax 032 655 71 74
e-mail etasdf@eta.ch

A company of **SMH**